

STRIKER

HYDRAULIC AUGERS

Manual ID: Drive Manual SA Series.indd
Revision Date: November 18, 2019

Owner's Manual
Parts Manual
Safety Precautions
Operating Instructions
Maintenance

Printed in the USA

SINGLE SPEED MODELS: SA-15 SA-30 SA-40



Top level part numbers are listed on
page 16.

PREFACE

This manual is used to familiarize you with safety, assembly, operation, adjustment, troubleshooting, and maintenance. Read and follow the recommendations in this manual to ensure safe and efficient operation. Keep this manual with the attachment at all times for future reference.

We want you to be completely satisfied with your new product, feel free to contact your local Authorized Service Dealer for help with service, replacement parts, or any other information you may require. If you need assistance in locating a dealer, visit our web site at www.toku-america.com or call customer service at 1-877-954-9923.

The descriptions and specifications in this manual are subject to change without notice. STRIKER reserves the right to improve products. Some product improvements may have taken place after this manual was printed. For the latest information on STRIKER attachments, visit our web site at www.toku-america.com or call customer service at 1-877-954-9923.

Thank you for buying and using STRIKER attachments!

TABLE OF CONTENTS

Preface / Table of Contents	2
Safety Statements	3
General Precautions	4
General Precautions Cont.	5
General Precautions Cont. (811 Information) / Serial Number Identification.....	6
Product / Equipment Precautions	7
Safety Decal Information	8
Product Specifications SA-15 /	9
Product Specifications SA-30 / SA-40	10
Typical Attachment Connections	11
Prime Mover Operating Positions (skid loader)	12
Prime Mover Operating Positions (skid loader)	13
Prime Mover Operating Positions (excavator).....	14
Prime Mover Operating Positions (excavator).....	15
Part Numbers All Models and Options	16
Set-Up / Hydraulic System Hook-Up / Operating Procedures	17
Operating Procedures Cont. / Maintenance Instructions.....	18
Maintenance Instructions / Storage Instructions.....	19
Checking and Changing Gear Oil	20
Troubleshooting	21
SA Series Parts Breakdown	22
SA Series Gearbox Parts Breakdown.....	23
Skid Loader Mount Parts Breakdown.....	24
Blank	25
Warranty Information	26
Torque Chart For Common Bolt Sizes	27

SAFETY STATEMENTS

DANGER



THIS STATEMENT IS USED WHERE SERIOUS INJURY OR DEATH WILL RESULT IF THE INSTRUCTIONS ARE NOT FOLLOWED PROPERLY.

WARNING



THIS STATEMENT IS USED WHERE SERIOUS INJURY OR DEATH COULD RESULT IF THE INSTRUCTIONS ARE NOT FOLLOWED PROPERLY.

CAUTION



THIS STATEMENT IS USED WHERE MINOR INJURY COULD RESULT IF THE INSTRUCTIONS ARE NOT FOLLOWED PROPERLY.



THIS SYMBOL BY ITSELF OR USED WITH A SAFETY SIGNAL WORD THROUGHOUT THIS MANUAL IS USED TO CALL YOUR ATTENTION TO INSTRUCTIONS INVOLVING YOUR PERSONAL SAFETY OR THE SAFETY OF OTHERS. FAILURE TO FOLLOW THESE INSTRUCTIONS CAN RESULT IN INJURY OR DEATH.

READ MANUAL PRIOR TO INSTALL

Improper installation, operation, or maintenance of the equipment could result in serious injury or death. Operators and maintenance personnel should read this manual as well as all manuals related to this equipment. **FOLLOW ALL SAFETY INSTRUCTIONS IN THIS MANUAL.**

WARNING



READ AND UNDERSTAND ALL SAFETY STATEMENTS

Read all safety decals and safety statements in all manuals prior to operating or working on this equipment. Know and obey all OSHA regulations, local laws and other professional guidelines for your operation. Know and follow good work practices when assembling, maintaining, repairing, mounting, removing or operating this equipment.



KNOW YOUR EQUIPMENT

Know your equipment's capabilities, dimensions and operations before operating. Visually inspect your equipment before you start, and never operate equipment that is not in proper working order with all safety devices intact. Check all hardware to assure it is tight. Make certain that all locking pins, latches, and connection devices are properly installed and secured. Remove and replace any damaged, fatigued or excessively worn parts. Make certain all safety decals are in place and are legible. Keep decals clean, and replace them if they become worn and hard to read.

WARNING



DO NOT MODIFY EQUIPMENT

Modifications may weaken the integrity of the equipment and may impair the functions, safety, life, and performance of the equipment. When making repairs, use only the manufacturer's genuine parts, following authorized instructions. Other parts may be substandard in fit and quality.



PREPARE FOR EMERGENCIES

- Be prepared if a fire starts.
- Keep a first aid kit near by when operating equipment.

GENERAL PRECAUTIONS

WARNING



OPERATOR SAFETY

- Protective clothing and equipment should be worn at all times.
- Wear protective clothing and equipment appropriate for the job. Avoid loose fitting clothing.
- Prolonged exposure to excessive noise can cause hearing loss. Wear suitable hearing protection such as ear plugs.
- Operating equipment safely requires the full attention of the operator. Avoid distractions.
- Do not operate the unit when you are tired, ill or under the influence of alcohol, drugs or medication.
- Never let a minor or inexperienced person operate the unit.
- Keep all body parts away from the drilling bit at all times.
- Inspect the area to be drilled before operation. Remove objects which can be thrown or become entangled.
- DO NOT operate the Drive attachment in areas where carbon monoxide fumes can accumulate.

CAUTION



PRODUCT SAFETY

- Inspect the entire product before operation.
- Replace parts that are cracked, chipped or damaged in any way before operation.
- Keep others away when making any adjustments to the unit.
- Damage to the Auger Drive and auger bit can result if the prime mover moves while the auger is still in the hole.

WARNING



PRACTICE SAFE MAINTENANCE

- Use proper tools and equipment when conducting maintenance.
- Work in a clean dry area.
- Inspect all parts. Be sure parts are in good working condition and installed properly.
- Remove build up of grease, oil or any debris.
- Remove all tools and unused parts from equipment before beginning operation.

WARNING



BE ALERT ON THE JOB SITE

Tragic accidents can occur if the operator is not alert to the presence of bystanders. Children in particular are often attracted to machinery and work activity. Never assume that children will remain where you last saw them. BE ALERT and turn the equipment off if children enter the work area. Keep children out of the work area and under supervision of another responsible adult.

WARNING



DRILLING SAFETY

- Inspect the area to be drilled before operation. Remove objects which can be thrown or become entangled. Be alert when drilling in locations where any type of landscaping fabric / mat may be present. The material can be rapidly drawn into the point of operation, possibly causing injury or death to anyone standing on or near the fabric.
- Keep all parts of your body away from the drilling bit when operating the unit.
- DO NOT operate the Auger Drive when the auger bit is more than 12" (305mm) above ground. The auger bit may bind and cause injury to the operator and damage to the equipment.
- While the auger bit is rotating, DO NOT attempt to manually guide the auger to a location.
- Ensure that overhead power / utility lines do not come into contact with the Drive attachment.
- DO NOT use a shovel or any other object to remove material from the auger bit or the hole while the Drive attachment is in use.

WARNING



UNDERGROUND HAZARDS

It is the responsibility of the operator to know where buried power, gas, telephone, and other utilities are at in the work area. This may lead to shock or an explosion. Have the work area marked for buried lines and do not dig in marked areas set by your local municipals. Striking a hard object underground with the auger turning can result in the slowing or stopping of the auger.

GENERAL PRECAUTIONS - CONTINUED

WARNING



LOWER OR SUPPORT RAISED EQUIPMENT

Do not work under raised booms without supporting them. Do not use support material made of concrete blocks, logs, buckets, barrels, or any other material that could suddenly collapse or shift positions. Make sure support material is solid, not decayed, warped, twisted, or tapered. Lower booms to ground level or on blocks. Lower booms and attachments to the ground before leaving the cab or operator's station. Whenever the boom structure must be raised for attachment installation or servicing block ensure the boom locking devices (if equipped) are deployed to prevent the accidental lowering of boom structures. NEVER PLACE ANY BODY PART BETWEEN THE PRIME MOVER CHASSIS AND THE BOOM STRUCTURE! Refer to the operating and maintenance instructions provided by the prime mover manufacturer for specific information.

WARNING



USE CARE WITH SILICA DUST DURING OPERATION

Concrete and masonry products contain silica sand. Quartz, which is a form of silica and the most common mineral in the earth's crust, is associated with many types of rock. Some activities that silica dust may be present in the air include demolition, sweeping, loading, sawing, hammering, drilling, or planing of rock, concrete or masonry.

It is recommended to use dust suppression, dust collection or personal protective equipment during the operation of any attachment that may cause high levels of silica dust. The NIOSH recommended exposure limit for respirable crystalline silica is 0.05 mg/m³ as a time-weighted average for up to 10 hours/day during a 40-hour workweek [NIOSH 1974].

WARNING



USE CARE WITH HYDRAULIC FLUID PRESSURE

Hydraulic fluid under pressure can penetrate the skin and cause serious injury or death. Hydraulic leaks under pressure may not be visible. Before connecting or disconnecting hydraulic hoses, read your prime mover's operator's manual for detailed instructions on connecting and disconnecting hydraulic hoses or fittings.

- Keep unprotected body parts, such as face, eyes, and arms as far away as possible from a suspected leak. Flesh injected with hydraulic fluid may develop gangrene or other permanent disabilities.
- If injured by injected fluid, see a doctor at once. If your doctor is not familiar with this type of injury, ask him to research it immediately to determine proper treatment.
- Wear safety glasses, protective clothing, and use a piece of cardboard or wood when searching for hydraulic leaks. DO NOT USE YOUR HANDS! SEE ILLUSTRATION.

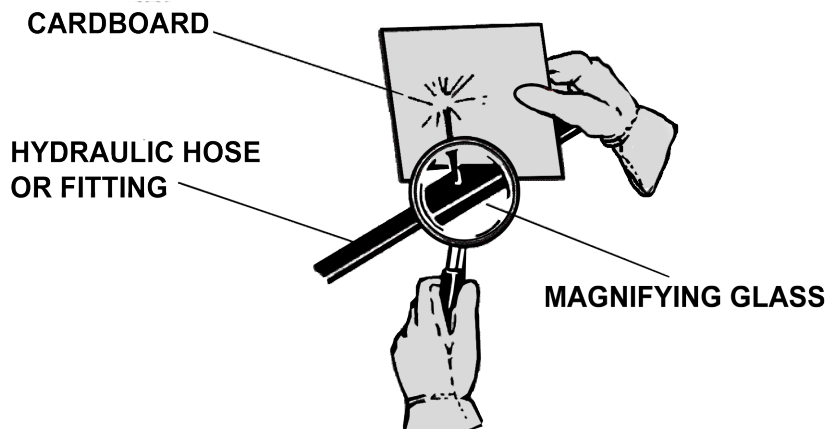

GENERAL PRECAUTIONS - CONTINUED



**Know what's below.
Call before you dig.**

One easy phone call to 811 starts the process to get your underground utility lines marked for free. When you call 811 from anywhere in the country (USA), your call will be routed to your local One Call Center. Local One Call Center operators will ask you for the location of your digging job and route your call to affected utility companies. Your utility companies will then send a professional locator to your location to mark your lines within a few days. Once your underground lines have been marked, you will know the approximate location of your utility lines and can dig safely, because knowing what's below protects you and your family.

Every state has different rules and regulations governing digging, some stricter than others. In addition, 62 separate One Call Centers serve different areas of the country; now 811 will connect you directly to your local one call center.

For more information go to www.call811.com

Always call 811 before starting any digging project!

**Customers outside the United States need to contact their local utility company for underground safety regulations specific to the area.

CALIFORNIA

Proposition

65



WARNING! California Proposition 65 Warning



This Product contains chemicals known to the State of California to cause cancer and birth defects or other reproductive harm. (California law requires this warning to be given to customers in the State of California.)

PRODUCT / EQUIPMENT PRECAUTIONS

CAUTION



PRIME MOVER LIFT CAPACITY

Alert yourself to the weight of the Drive Unit. **DO NOT** exceed the recommended lift capacity of the prime mover. Refer to your prime mover's owners manual for suggested lift capacity and lift considerations.

WARNING



PRIME MOVER / ATTACHMENT INSTALLATION

Ensure all connection pins, fasteners and latches are properly secured. **Ensure that the mounting frame / attachment mounting plate is rigidly secured to the prime mover.** Improper installation can result in product damage, personal injury and death.

Ensure all hydraulic hose assemblies are of adequate length and have enough slack for full Drive attachment movement. Failure to provide adequate length hydraulic hoses can result in hose rupturing. A hydraulic hose rupture can result in product damage, personal injury and death.



OPERATING THE PRIME MOVER

Avoid steep hillside operation, which could cause the prime mover to overturn. Consult your prime mover operator's and safety manuals for maximum incline allowable.

WARNING



TRANSPORTING THE DRIVE ATTACHMENT

- Travel only with the Drive attachment in a safe transport position to prevent uncontrolled swinging.
- Tether the Drive attachment with a chain, if necessary, to prevent uncontrolled swinging of the auger when moving from hole to hole.
- Remove the earth auger or helical anchor from the Drive attachment before transporting to and from the job site.
- Use extreme care during transport to prevent contact between the Drive attachment and bystanders or solid objects. Contact with the Drive attachment could cause serious damage, injury or death.
- Never operate the Drive attachment while transporting.
- Drive slowly over rough ground and on slopes. Position the Drive attachment as low to the ground as possible maintaining a low center of gravity.

CAUTION



DRIVE ATTACHMENT SIDE LOADING

Side loading is NOT recommended. Excessive side loading can cause output shaft deflection and or failure. Avoid excessive side loading to prevent possible instantaneous output shaft failure. Such a failure could result in injury from disconnected parts and or being hit by the Drive attachment causing serious injury or death.

SERIAL NUMBER IDENTIFICATION

Its important to make the correct reference to the serial number of the unit when making repairs or ordering parts. The serial number plate will be located near the top of the Auger Drive attachment.

Example Serial Tag used on STRIKER HYDRAULIC AUGER Drive Attachments

STRIKER		C E	
HYDRAULIC AUGER			
MODEL	SA30	PART NO	623123
SERIAL NUMBER	50102030		
DATE OF MFG	AUGUST 2018		
WEIGHT	130 LBS	MADE IN	USA
TOKU-AMERICA.COM			

Figure 1

SAFETY DECAL INFORMATION



SAFETY DECALS

This unit comes equipped with all safety decals in place. They are designed to help you safely operate your unit. Read and follow all safety decals.

- Keep all safety decals clean and legible at all times.
- Replace safety decals that are missing or have become illegible.
- Safety decal kits are available from your distributor or manufacture.
- Some parts installed during repair may require safety decals to be affixed to the replacement part. When ordering the replacement part(s) be sure the correct safety decal kit is included in your order.



INSTALLING SAFETY DECALS

- Clean the desired area with warm soapy water.
- Decide on exact position before you remove the backing paper.
- Peel backing paper from decal. Press firmly on the surface.
- Air pockets can be pierced with a pin and smoothed.

Typical Decal used on STRIKER HYDRAULIC AUGER Drive Attachments



Figure 2

PRODUCT SPECIFICATIONS

AUGER DRIVE MODEL	
SA-15	
TOTAL UNIT WEIGHT	130 LBS / 59 Kg
HYDRAULIC MOTOR INFORMATION	
Displacement	12.1cu/in (198cc)
Motor Type	Single Speed Bi-Directional
Motor Output Shaft	1-1/4" Spline 14T
Motor Mount	SAE - A 2 Bolt
Motor Ports	7/8"-14 O-ring
Cross Over Pressure Relief	Not Equipped
PLANETARY GEARBOX INFORMATION	
Gearbox Type	Planetary Single Stage
Reduction Ratio	3.82:1
Output Shaft	2" Hex
Oil Capacity	25 oz
Oil Type	SAE 80W90 GL-5
Shaft Pull Out (lbs.)	2,000 lbs.
REFERENCE TORQUE CHART	
Pressure PSI (Bar)	Torque (ft/lbs)
1200 (82)	639
1400 (96)	746
1600 (110)	852
1800 (124)	959
2000 (137)	1065
2200 (151)	1172
2400 (165)	1278
2600 (179)	1385
2800 (193)	1491
3000 (206)	1598
3200 (220)	1704
3400 (234)	1811
3600 (248)	1917
REFERENCE SPEED CHART	
Flow GPM (Liter)	Speed (rpm)
5 (19)	21
10 (38)	43
15 (56)	65

Output speed and torque specifications are listed at 100% efficiency. Speed and torque output are dependent on the overall system efficiencies associated with the prime movers hydraulic system. When the purchaser is determining criteria for specific applications please contact Striker. Striker has made every attempt to present accurate and suitable information published on this document. This document should be used for information and comparative purposes only. When application specific information is required, please contact Striker.

Striker continually looks for new ways to improve its products. Therefore, Striker reserves the right to make changes to our products and specifications without notice.

PRODUCT SPECIFICATIONS

AUGER DRIVE MODEL	
SA-30	
TOTAL UNIT WEIGHT	130 LBS / 59 Kg
HYDRAULIC MOTOR INFORMATION	
Displacement	18.3 cu/in (300cc)
Motor Type	Single Speed Bi-Directional
Motor Output Shaft	1-1/4" Spline 14T
Motor Mount	SAE - A 2 Bolt
Motor Ports	7/8" - 14 O-Ring
Cross Over Pressure Relief	Not Equipped
PLANETARY GEARBOX INFORMATION	
Gearbox Type	Planetary Single Stage
Reduction Ratio	3.82:1
Output Shaft	2" Hex
Oil Capacity	25 oz
Oil Type	SAE 80W90 GL-5
Shaft Pull Out (lbs.)	2,000 lbs.
REFERENCE TORQUE CHART	
Pressure PSI (Bar)	Torque (ft/lbs)
1200 (82)	1113
1400 (96)	1299
1600 (110)	1484
1800 (124)	1670
2000 (137)	1855
2200 (151)	2041
2400 (165)	2227
2600 (179)	2412
2800 (193)	2598
3000 (206)	2784
3200 (220)	2969
3400 (234)	3154
3600 (248)	3340
REFERENCE SPEED CHART	
Flow GPM (Liter)	Speed (rpm)
15 (56)	49
20 (75)	66
25 (95)	82
30 (113)	99

AUGER DRIVE MODEL	
SA-40	
TOTAL UNIT WEIGHT	130 LBS / 59 Kg
HYDRAULIC MOTOR INFORMATION	
Displacement	21.2 cu/in (347cc)
Motor Type	Single Speed Bi-Directional
Motor Output Shaft	1-1/4" Spline 14T
Motor Mount	SAE - A 2 Bolt
Motor Ports	7/8" - 14 O-Ring
Cross Over Pressure Relief	Not Equipped
PLANETARY GEARBOX INFORMATION	
Gearbox Type	Planetary Single Stage
Reduction Ratio	3.82:1
Output Shaft	2" Hex
Oil Capacity	25 oz
Oil Type	SAE 80W90 GL-5
Shaft Pull Out (lbs.)	2,000 lbs.
REFERENCE TORQUE CHART	
Pressure PSI (Bar)	Torque (ft/lbs)
1200 (82)	1287
1400 (96)	1502
1600 (110)	1717
1800 (124)	1931
2000 (137)	2146
2200 (151)	2361
2400 (165)	2575
2600 (179)	2790
2800 (193)	3005
3000 (206)	3219
3200 (220)	3434
3400 (234)	3649
3600 (248)	3863
REFERENCE SPEED CHART	
Flow GPM (Liter)	Speed (rpm)
20 (75)	57
25 (95)	71
30 (113)	85
35 (132)	99

Output speed and torque specifications are listed at 100% efficiency. Speed and torque output are dependent on the overall system efficiencies associated with the prime movers hydraulic system. When the purchaser is determining criteria for specific applications please contact Striker. Striker has made every attempt to present accurate and suitable information published on this document. This document should be used for information and comparative purposes only. When application specific information is required, please contact Striker.

Striker continually looks for new ways to improve its products. Therefore, Striker reserves the right to make changes to our products and specifications without notice.

TYPICAL ATTACHMENT CONNECTIONS



IMPORTANT: Before connecting the attachment to prime mover, inspect all mounting surfaces, attachment plates, and quick couplers are free of dirt and debris. Ensure all attaching pins, fasteners and latches are properly secured. Ensure that the mounting frame / attachment mounting plate is rigidly secured to the prime mover. Improper installation can result in product damage, personal injury and death.

1 EXCAVATOR / BACKHOE MOUNT END OF BOOM (Figure 3)

Mounting Bracket connects directly to the boom with the customer supplier connection pin. The Drive Unit connects to the Mounting Bracket with the supplied connection pin.



Figure 3

2 EXCAVATOR / BACKHOE MOUNT QUICK COUPLER (Figure 4)

Mounting Bracket connects to the quick coupler when the jaws of the quick coupler engage the pins on the Mounting Bracket. The Link Arm connects to both the Mounting Bracket and the Drive Unit with the supplied connection pins.



Figure 4

3 SKID LOADER MOUNT ATTACHMENT PLATE (Figure 5)

Attachment Plate connects to the mounting plate on the front of the Skid Loader. The Link Arm connects to both the Attachment Plate and the Drive Unit with the supplier connection pins.

These three images represent the three most common attachment connections.

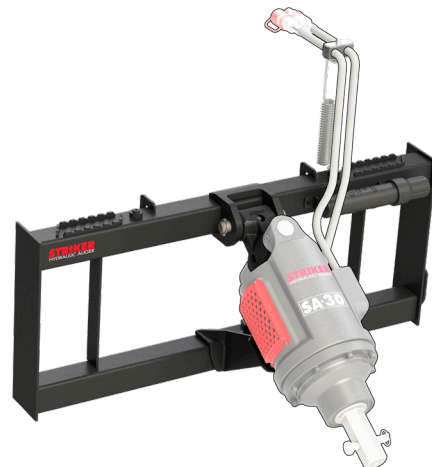

Figure 5

PRIME MOVER OPERATING POSITIONS

These illustrations represent the recommended working, transport and resting positions for your STRIKER HYDRAULIC AUGER Drive attachment when used with a skid loader prime mover.



Drive torque capacity limited to **12,000 ft/lbs Max** when used on skid loader.

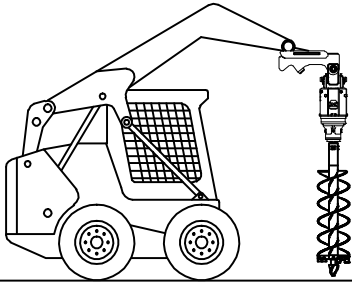

A) Recommended: Starting Position
Position the Drive and Auger vertically in desired location and begin drilling.

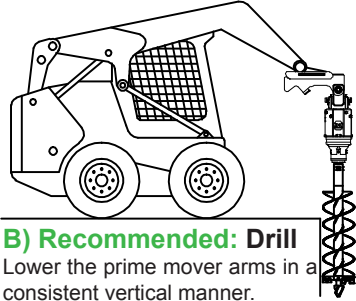

B) Recommended: Drill
Lower the prime mover arms in a consistent vertical manner.

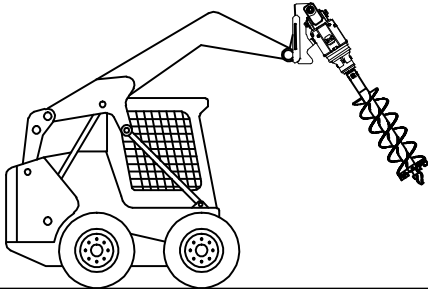

C) Recommended: Transport Position
Cradle the Drive against the mounting frame during transport on the job site.

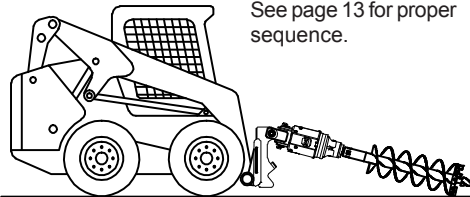

D) Recommended: Resting / Parked
Park the prime mover with the Auger on the ground.

See page 13 for proper sequence.

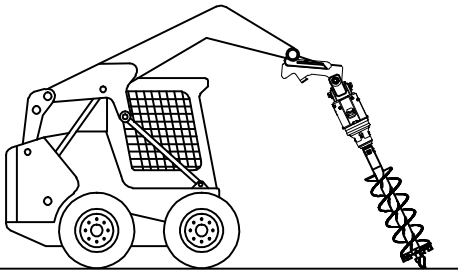

E) Avoid: Drilling Position
Avoid any drilling position that is not vertical. Auger will be unstable and not easily controlled.

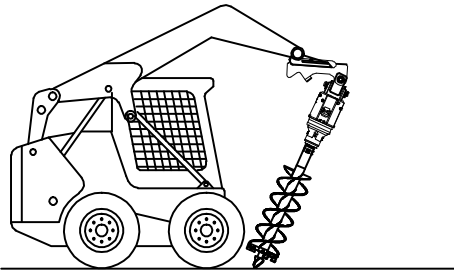

F) Avoid: Drilling Position
Avoid any drilling position that is not vertical. Auger will be unstable and not easily controlled.

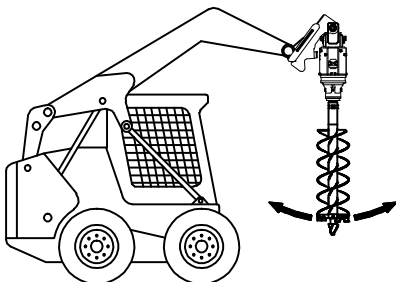

G) Avoid: Transport Position
Avoid transporting the Auger in a suspended free swinging position. Damage can occur.

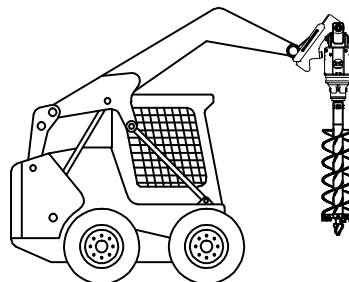

H) Avoid: Resting / Parked Position
Avoid parking the prime mover with Drive and Auger in a suspended position.

PRIME MOVER OPERATING POSITIONS

These illustrations represent the recommended sequence for positioning the Drive attachment in a resting and or transport position. It is important that the recommendations are followed to prevent damage to the attachment and ensure safety.

Starting Position

Position the Drive and Auger vertically in desired location. Allow for ample room to maneuver the prime mover.

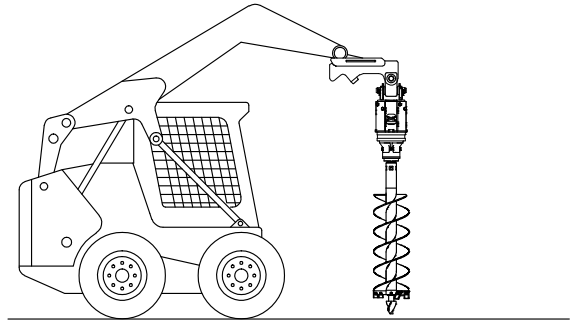

Transition Position

In order to safely position the attachment in a resting position the following steps will need to be completed simultaneously.

1. Lower the prime mover arms.
2. Rotate the attachment plate back towards the cab.
3. Maneuver the prime mover in reverse.

During this process the point of the Auger should not lose contact with the ground. Failure to follow this sequence can result in damage. Do not put the auger in a binding situation, this will cause damage to the Drive output shaft!

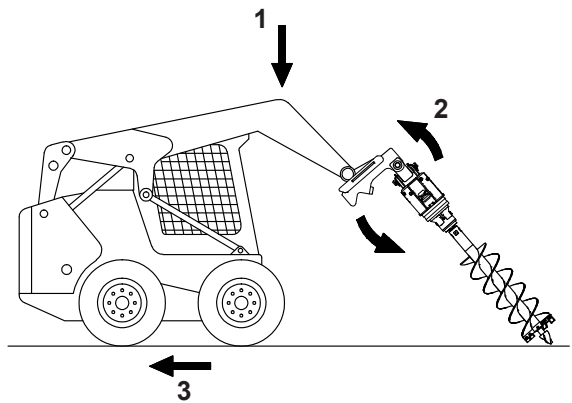

Resting Position

When the attachment plate reaches its lower most position the attachment is now in its resting position.

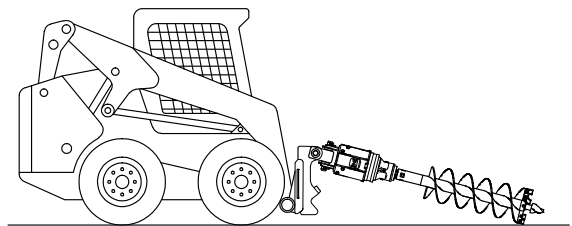

IMPORTANT

Damage to the Drive output shaft can occur if operating instructions are not followed.

PRIME MOVER OPERATING POSITIONS

These illustrations represent the recommended working, transport and resting positions for your STRIKER HYDRAULIC AUGER Drive attachment when used with an excavator prime mover.

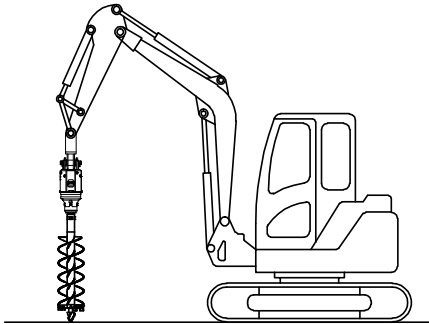

A) Recommended: Starting Position
Position the Drive and Auger vertically in desired location and begin drilling.

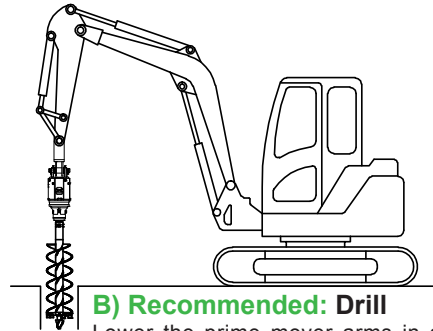

B) Recommended: Drill
Lower the prime mover arms in a consistent vertical manner.

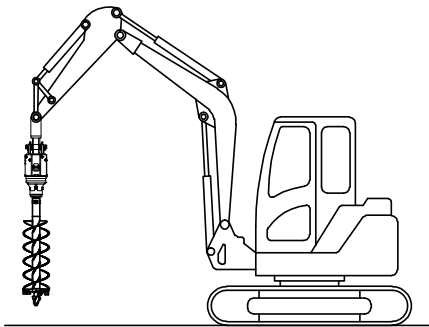

C) Recommended: Transport Position
Lift the Auger off the ground during transport on the job site. Keep Auger as low as possible.

See page 15 for proper sequence.

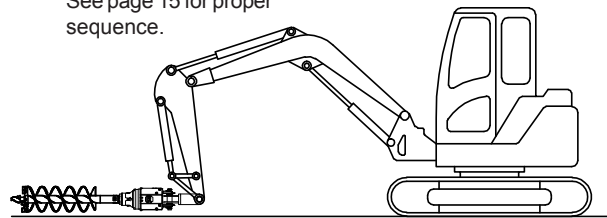

D) Recommended: Resting / Parked
Park the prime mover with the Auger on the ground.

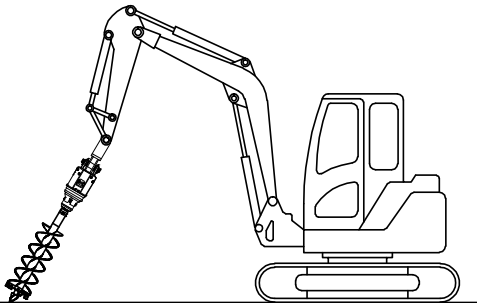

E) Avoid: Drilling Position
Avoid any drilling position that is not vertical. Auger will be unstable and not easily controlled.

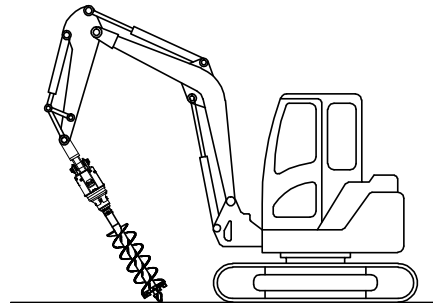

F) Avoid: Drilling Position
Avoid any drilling position that is not vertical. Auger will be unstable and not easily controlled.

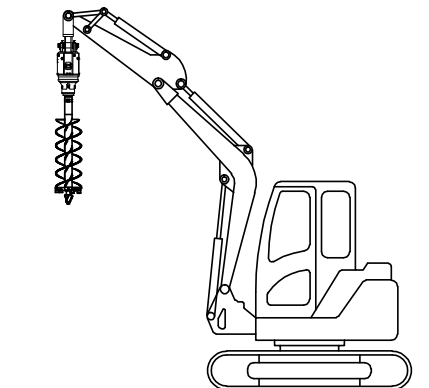

G) Avoid: Transport Position
When transporting the Auger on the job site do not allow the Auger to swing in an uncontrolled manner. Damage can occur to the attachment and prime mover.

H) Avoid: Resting / Parked Position
Avoid parking the prime mover with the Drive and Auger in a suspended position.

PRIME MOVER OPERATING POSITIONS

These illustrations represent the recommended sequence for positioning the Drive attachment in a resting and or transport position. It is important that the recommendations are followed to prevent damage to the attachment and ensure safety.

Starting Position

Position the Drive and Auger vertically in desired location. Allow for ample room to maneuver the prime mover.

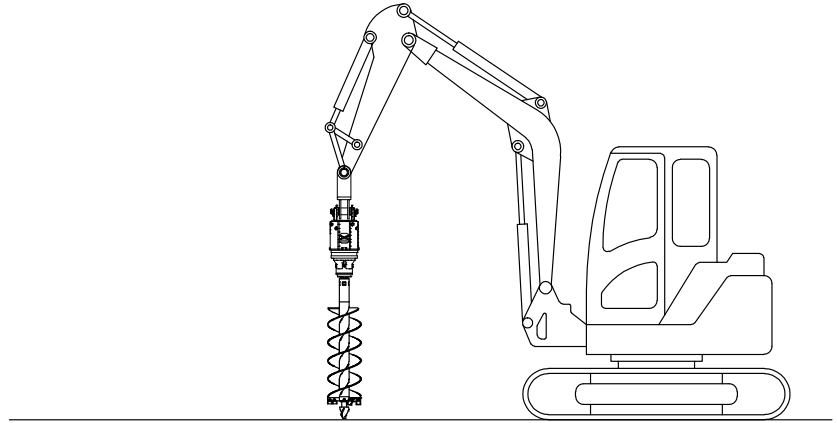

Transition Position

In order to safely position the attachment in a resting position the following steps will need to be completed simultaneously.

1. Lower the prime mover boom.
2. Allow the Drive and Auger to rotate towards the ground.
3. Maneuver the prime mover in reverse.

During this process the point of the Auger should not lose contact with the ground. Failure to follow this sequence can result in damage. Do not put the Auger in a binding situation, this will cause damage to the Drive output shaft!

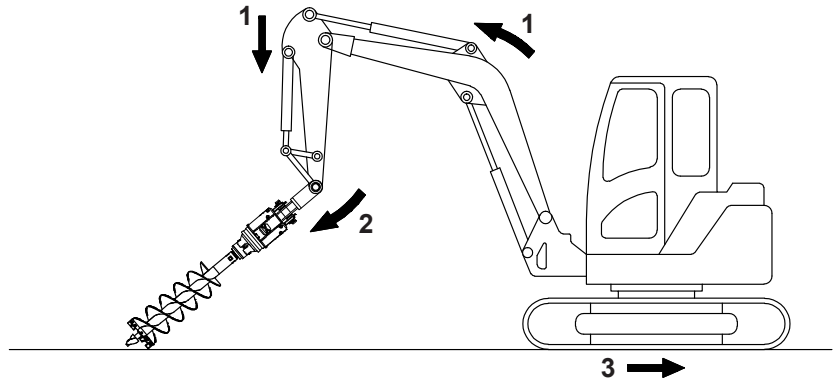

Resting Position

When the Drive and Auger are in full contact with the ground the attachment is now in its resting position.

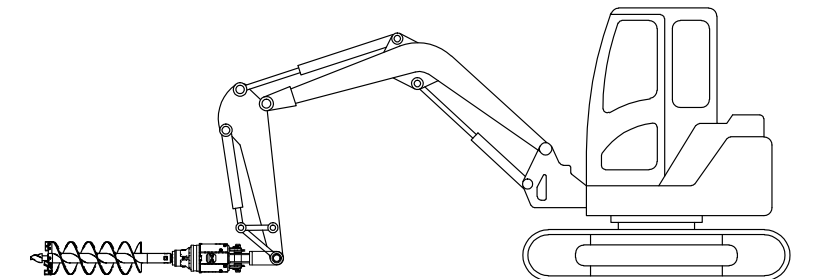

IMPORTANT

Damage to the Drive output shaft can occur if operating instructions are not followed.

PART NUMBERS - ALL MODELS AND CONFIGURATIONS

AUGER DRIVE MODEL	
SA-15	
Top Level Part Numbers	
Part Number	Description
SA-15	Drive Unit with Hyd Hoses
SA-15-SSL	Drive Unit With SSL Mount and Hoses

AUGER DRIVE MODEL	
SA-30	
Top Level Part Numbers	
Part Number	Description
SA-30	Drive Unit with Hyd Hoses
SA-30-SSL	Drive Unit With SSL Mount and Hoses

AUGER DRIVE MODEL	
SA-40	
Top Level Part Numbers	
Part Number	Description
SA-40	Drive Unit with Hyd Hoses
SA-40-SSL	Drive Unit With SSL Mount and Hoses

SET-UP INSTRUCTIONS

READ AND UNDERSTAND ALL SAFETY INFORMATION PRIOR TO MOUNTING YOUR DRIVE UNIT TO THE PRIME MOVER. SEE PAGES 7 & 12.

MOUNTING AND INSTALLATION

There are several ways to mount your Drive Unit depending on the prime mover and application.

A) Skid Steer Mounting (Quick Attach)

1. Remove the skid steer bucket or any other attachment from the skid steer quick attach mechanism.

2. Attach the quick attach mounting bracket to the skid steer

B) Backhoe and Excavator Mounting

1. Remove the bucket from the dipper arm and curl cylinder pin connections.

AUGER CONNECTION

1. Align the auger bit with the output shaft of the Drive Unit.

2. Slide the connecting coupler (hub) over the output shaft and align the coupler hole with the output shaft hole.

3. Connect the auger bit to the Drive Unit output shaft and secure it with appropriate connecting hardware.

When selecting connecting hardware ensure that the

WARNING *bolt or pin does not protrude from the coupler (hub) any more than necessary to secure. Hardware that protrudes an excessive amount can be a safety hazard and cause entanglement.*



HYDRAULIC SYSTEM HOOK-UP

Your Striker Planetary Drive Unit receives its hydraulic oil flow and pressure from the prime mover through the auxiliary hydraulic circuit via two quick release couplers near the end of the truck boom or excavator arm. Follow the steps below to complete the hydraulic hook-up between your prime mover and Drive Unit.

HYDRAULIC SYSTEM HOOK-UP

1. Locate the auxiliary hydraulic connection ports on the prime mover.

2. Determine the length of hydraulic hose necessary to connect the auxiliary hydraulic circuit to the Drive Unit. Be sure to allow sufficient “slack” in the hose length to allow the Drive Unit to perform its full range of operation.

3. Ensure that the hydraulic hose couplers are compatible with the hydraulic quick couplers on the Drive Unit.

WARNING



If a hydraulic leak develops, correct it immediately. Escaping hydraulic fluid can have extremely high pressure. A stream of high pressure fluid may penetrate the skin. It is imperative that the connections are tight and that all hoses are in good working condition.

4. Once all of the hydraulic connections have been made and checked for leaks, the Drive Unit is ready for operation.

CAUTION



Hydraulic hoses and fittings used on the prime mover and Drive Unit must have a continuous operating pressure rating of at least 25% higher than the maximum pressure of the hydraulic system being used. Refer to the Drive Unit specification chart for allowable maximum pressure.

OPERATING PROCEDURES

Before operating, always ensure that the Drive Unit and auger are connected correctly to the prime mover.

DRILLING OPERATION

1. To begin drilling/installation, position the auger or anchor on the ground in the desired location. Engage the parent machine's auxiliary hydraulics to rotate the auger in a clockwise direction.

2. Lower the parent machine's arm(s) to engage the auger into the ground. Use only enough down pressure to assure positive penetration. Ease up on the down pressure if the auger or anchor rotation slows down drastically or stalls. Excessive down pressure will cause the Drive Unit to stall frequently.

Note: *Do not continually stall the Drive Unit! Continued stalling may cause excessive heating of the hydraulic system and possible damage to the Drive Unit.*

3. As the auger digs in the ground, the prime mover's arm(s) or boom may travel through an arc. This means the operator may need to continually reposition the auger to ensure vertical application of the auger.

OPERATING PROCEDURES CONT.

4. When the auger has penetrated the ground about 24" (610mm), raise the auger from the hole to clean out the loose material.

5. Once the required hole depth is reached, allow the auger to turn a few seconds at this depth to clean the hole.

6. Stop rotation of the auger and raise the auger out of the hole. Swing the auger away from the newly drilled hole. Spin the loose material off the auger.

Note: Do not reverse the auger rotation while the auger is still in the hole. The loose material will back fill the hole.

If necessary, repeat steps 4 through 6 to obtain a cleaner hole.

OPERATIONS TO AVOID

1. In some soil conditions or when excessive down pressure is applied, the auger may "screw" itself into the ground. This can cause the auger to become stuck causing the Drive Unit to stall. If this situation occurs, reverse the auger rotation and slowly raise the auger from the hole.

2. If the auger becomes lodged under rocks, tree roots, or other large obstructions, do not attempt to raise the auger out of the ground. See Step 1 of this section to relieve the auger.

3. Avoid excessive side loading. This can cause damage to both the Drive Unit and the auger bit.

4. Keep all auger teeth and pilot bits in good condition. Avoid using damaged teeth and holders.

MAINTENANCE INSTRUCTIONS

Before operating the Drive Unit ensure it is properly lubricated and inspected for any worn or damaged areas. Only a minimum amount of time and effort is required to regularly lubricate and maintain the Drive Unit. Preventive maintains will help ensure long life and trouble free operation.

LUBRICATION MAINTENANCE

The Drive Unit must be properly lubricated to achieve the most efficient operation. Clean excess grease, gear oil, and hydraulic fluid from the Drive Unit. This is especially important in sandy conditions.

HYDRAULIC OIL MAINTENANCE

CLEAN HYDRAULIC OIL IS ESSENTIAL!

80% of all hydraulic component failures are caused by Contamination of the hydraulic oil. Always keep all dirt and other contaminants from entering the hydraulic system during disconnect and connect operations. Always use dust caps and plugs on all quick disconnects when not in use. Tightly cap all hydraulic openings to hold oil in and keep dirt and other contaminants from entering hydraulic systems.

HYDRAULIC HOSE MAINTENANCE

Inspect all hydraulic hoses daily for cracked and brittle covers caused by excessive heat. Reduced viscosity of hydraulic oil occurs at higher operating temperatures and causes a breakdown of fluid additives, such as wear inhibitors. Excessive heat will cause higher internal leakage in the Drive Unit motor, which will make the Drive Unit less efficient. It can also cause seals in the drive unit motor to become brittle and crack. Replacement of hoses before failure will prevent loss of hydraulic oil and down time.



IMPORTANT

Refer to pages 12-15 for illustrations on correct operating positions.

MAINTENANCE INSTRUCTIONS

GEARBOX MAINTENANCE

The planetary gearbox is filled with gear oil lubricant. If oil is observed leaking, the seal should be inspected for damage or wear and replaced if necessary. Inspect the gearbox for any other possible damage that could be causing the leakage.

Change planetary gear oil after the first 50 hours of operation. Change the gear oil every 1000 hours or 12 months whichever occurs first. *CHECK OIL LEVEL DAILY* to assure proper lubrication is maintained. See the CHECKING AND CHANGING GEAR OIL section for gear oil grade.

HARDWARE MAINTENANCE

Check Drive Unit and all accessories daily for loose, bent, cracked, or worn bolts and fasteners. Always use Grade 5 or harder replacements bolts. Always use lock washers with standard hex nuts or self locking nuts.

Check all connecting pins daily for bends, cracks, breaks, or wear. Replace if any of these conditions exist.

OUTPUT SHAFT MAINTENANCE

Check the Drive Unit output shaft daily for cracks or excessive wear near or around the connection hole. The output shaft should be replaced if any of these conditions exist.

Where replacement parts are necessary for periodic maintenance and servicing, genuine factory replacement parts must be used to restore your unit to original specifications. Manufacturer will not claim responsibility for use of unapproved parts or accessories and other damages as a result of their use.

If equipment has been altered in any way from its original design, manufacturer does not accept any liability for injury or warranty.

STORAGE INSTRUCTIONS

When the Drive Unit will not be used for an extended period of time, it should be thoroughly checked and prepared for storage so that a minimum amount of work will be required to put the Drive Unit back into operation. The following are suggestions for storage:

1. Thoroughly clean the Drive Unit.
2. Ensure the hydraulic motor and the hoses are full of clean oil. Be sure the planetary gearbox is full (to the recommended capacity for each model).
3. Tighten all bolts and pins to the recommended torque values.
4. Protect the output shaft with grease or a rust inhibitor.
5. Check the Drive Unit for worn or damaged parts.
6. Store the Drive Unit away from active areas and in a clean dry location.
7. Paint all scratched or bare metal surfaces.

CHECKING / CHANGING GEAR OIL

The Planetary gearbox used on your Drive Unit uses gear oil to keep the internal gears lubricated. To check and or replace the oil, follow the steps below.

CHECKING THE GEAR OIL:

1. Make sure the Drive Unit is in an upright position when checking the oil.
2. Remove the Oil Fill Port plug and visually inspect that oil can be seen. If oil can be seen this is an indication that the oil level is adequate.

CHANGING THE GEAR OIL:

1. Arrange the Drive Unit in a position in which the oil can flow freely from the gearbox once the drain plug is removed. It is recommended that the Oil Fill Port plug be removed to act as a vent so the oil will drain quickly.
2. Place a drain pan under the drain port.
3. Remove the Drain plug and allow the oil to completely drain out. Allow 10-15 minutes for oil to drain completely.
4. Position the gearbox for filling by orientating the unit so that the oil fill port is accessible. In some cases the bail housing will need to be removed to access the oil fill port, which is located in the top section of the gearbox, near the motor.
5. Replace Oil Drain Port and fill the gearbox with the required amount of gear oil. Gear oil specification listed below:

Lubrication Recommendations:

SAE 80W90 GL-5 Oil

Density / 15 deg C:	0.895
Viscosity Index:	97
Viscosity @ 40 deg C:	138
Flash Point COC:	200
Viscosity @ 100 deg C:	13.9
Pour Point (deg C):	-30

Gearbox Capacity:

25 oz (All CS Series Models)

The housing vent located on the side of the housing will need to be removed to allow access to all ports during oil change.

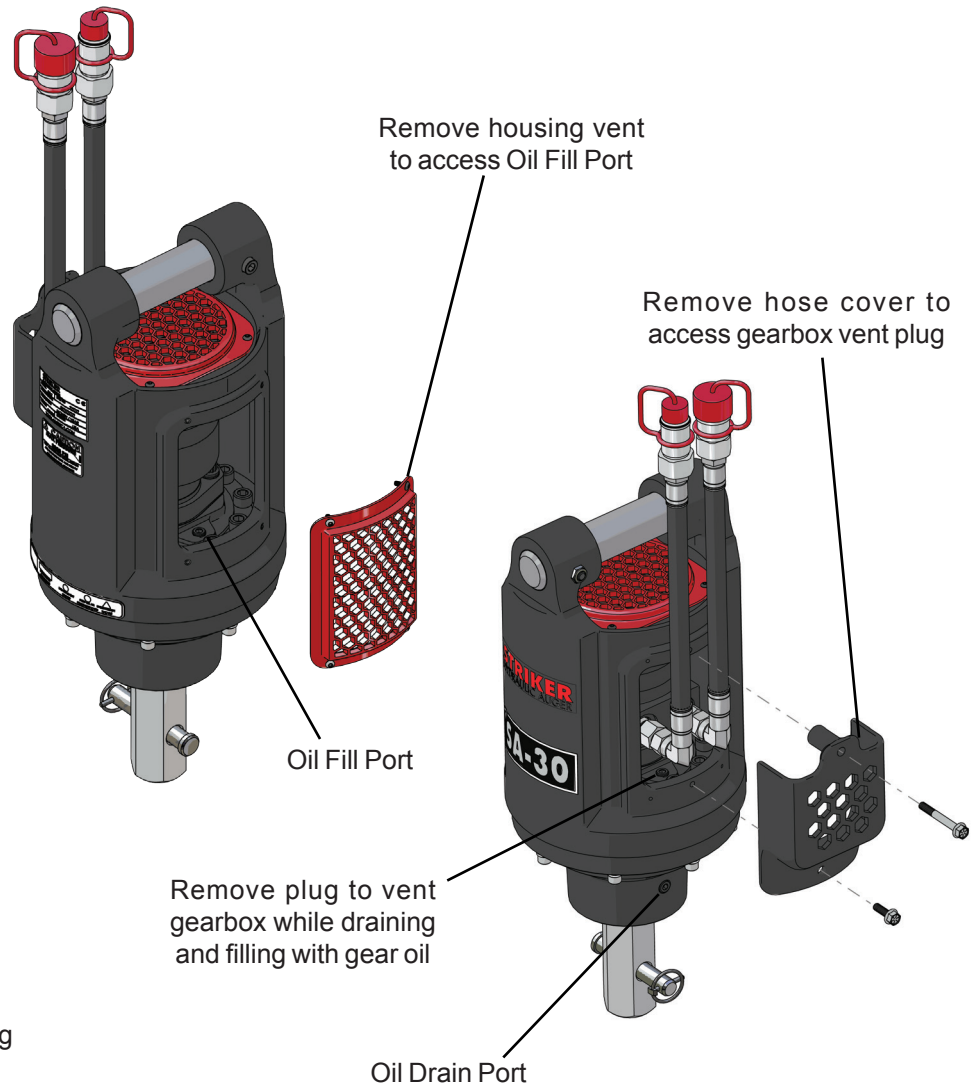

Figure 6

IMPORTANT!

DO NOT overfill gearbox when replacing the gear oil. Excessive amount of gear oil will reduce the amount of room in the gearbox for expansion and cause damage to the seals.

TROUBLESHOOTING

In the event your Striker Hydraulic Auger Drive Unit malfunctions or does not appear to have enough speed or power, please refer to the section below to identify the cause of the problem and possible remedy. If the problem persists, contact your Authorized Service Dealer for assistance.

SLOW SPEED (RPM) OR INSUFFICIENT DIGGING POWER:

- Low oil flow / Obstructed oil flow. *Check prime mover pump. Check for faulty pressure relief valve.*
- Auger Drive is too large for machine. *Review Drive Unit specs. Contact your Authorized Service Dealer.*
- Check auger and teeth for excessive wear. *Replace worn auger components.*

NO OUTPUT ROTATION:

- Quick release couplers not engaged. *Check coupler connection.*
- Quick release coupler faulty. *Replace faulty coupler(s).*
- Hydraulic oil tank is low. *Fill oil tank to maximum level.*
- Planetary gear failure. *Contact your Authorized Service Dealer.*
- Machine oil pump failure. *Refer to prime mover manual.*
- Insufficient oil flow. *All two speed models require a min of 20 GPM to operate.*

BAIL HOUSING LEAKING OIL:

- Hose(s) of Fitting(s) leaking. *Tighten or replace.*
- Motor O-ring failure. *Replace damaged O-ring.*

OUTPUT SHAFT LEAKING OIL:

- Output shaft seal damaged. *Replace seal.*
- Seal not sealing in the housing. *Replace seal or use a sealant on OD of seal.*
- Bolts are loose. *Tighten Bolts.*

AUGER / ANCHOR BIT WILL NOT ENGAGE OR DIG:

- Auger bit is worn or damaged. *Replace cutting head or entire auger bit.*
- Drive Unit speed is too fast. *Reduce speed (rpm) to allow bit to engage ground.*
- Anchor not installing vertically. *Level Drive unit. Allow Drive unit to hang freely.*

NO TORQUE:

- Oil pressure is too low. *Review Drive unit pressure requirements.*
- Drive unit too small for parent machine. *Review Drive Unit specs. Contact your Authorized Service Dealer.*
- Hydraulic system is overheating. *See the "Oil Overheating" section below.*

HYDRAULIC OIL OVERHEATING:

- Oil pressure is too low. *Set relief valve to machine specifications.*
- Hydraulic line is restricted. *Inspect and repair.*
- Auger continually stalling. *Limit down pressure used.*
- Hydraulic oil tank is low. *Fill oil tank to maximum level.*
- Oil passing over relief valve. *Check for a faulty relief valve.*
- Prime Mover is too small. *Attach Drive Unit to larger prime mover.*
- Dirty or contaminated oil. *Replace prime mover hydraulic oil and oil filters.*

SA SERIES PARTS BREAKDOWN

ITEM	PART No.	QTY	DESCRIPTION
1	623110	1	GEARBOX RE 241 TE 2" 3.82 12/24 DP Z14
2	623065	1	BAIL CS SERIES
3	160415	8	WASHER LOCK 3/8"
4	132043	8	CAP SCREW 3/8-16 X 1-3/4 G8
5	620024	1	PIN 45MM CS SERIES
6	610298	1	NUT HEX LOCK M10X1.5
7	623109	1	HOUSING VENT BAIL TOP
8	610562	1	HOSE KIT CS SERIES
9	SEE NOTE	1	DECAL MODEL NUMBER
10	610739	1	SCREW SOC HEAD M10 X 75
11	350324	1	DECAL CAUTION 3000 PSI
12	623108	1	HOUSING VENT BAIL
13	135015	1	AUGER PIN ASSY 3/4"
14	350378	1	SERIAL TAG
15	623059	8	SCREW HEX BUTTON 10-24 X 1/2"
16	350266	1	DECAL DANGER AUGER DRIVE
17	SEE NOTE	1	HYD MOTOR
18	*350359	1	TAG DRIVE INFORMATION STRIKER
19	623120	1	COVER CS DRIVE HOSE PROTECTOR
20	623119	1	SCREW, HEX FLG G8 5/16 X 1" BLACK
21	623129	1	SCREW, HEX FLG G8 5/16 X 2-1/2" BLACK
22	350364	1	DECAL STRIKER LOGO DRIVE BAIL

* Indicates item not shown

MOTOR COMPONENTS:
Items related to motor assembly:

Part No.	Qty	Description
*660802	1	SPACER SAE-A
*623058	4	SCREW 1/2"-13
*139211	4	LOCK WSHR 1/2"
*660598	2	GASKET SAE-A

HYDRAULIC MOTOR:
Item 17 is model specific:

Model	Part No.	Description
SA-15	623002	MOTOR 198CC
SA-30	623004	MOTOR 300CC
SA-40	623005	MOTOR 347CC
ALL	660598	GASKET SAE-A

MODEL DECAL:
Item 9 is model specific:

Model	Part No.	Description
SA-15	350360	SA-15 DECAL
SA-30	350361	SA-30 DECAL
SA-40	350362	SA-40 DECAL

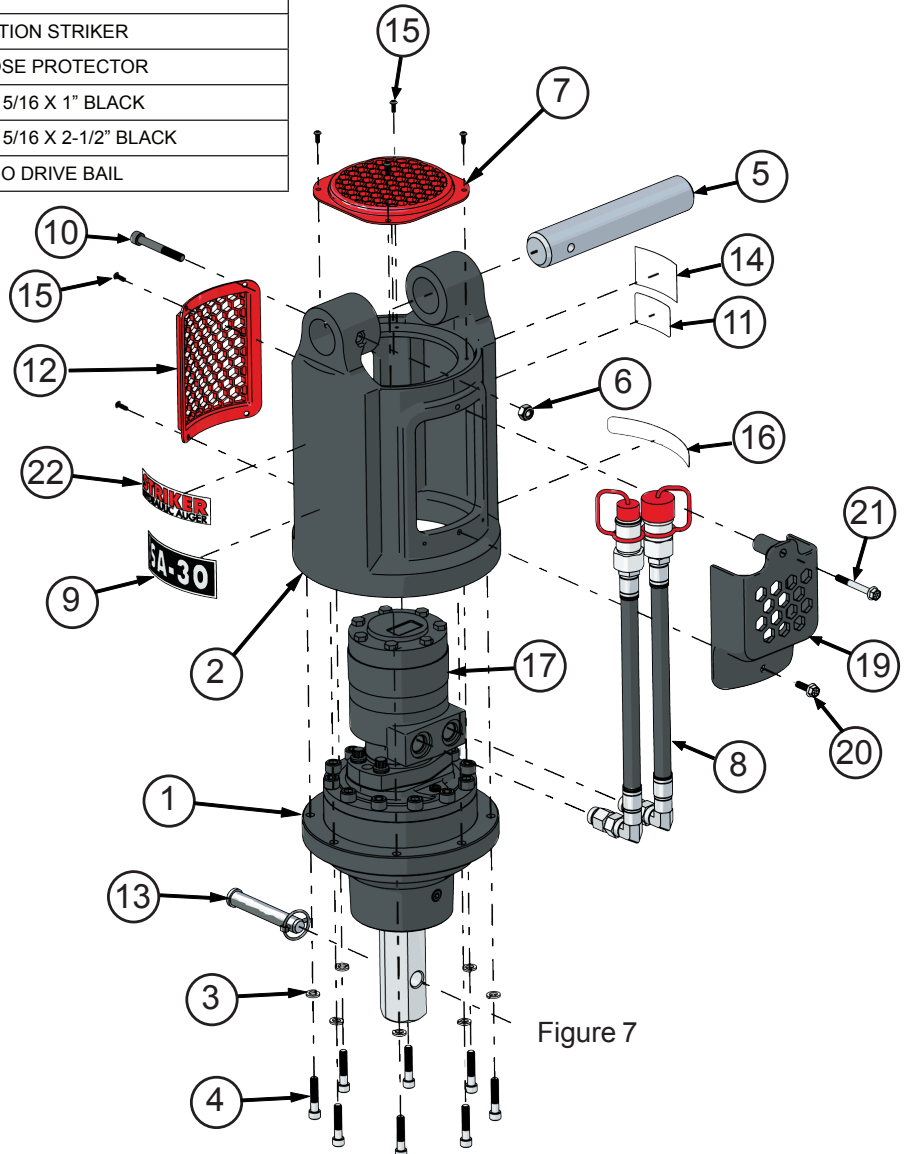
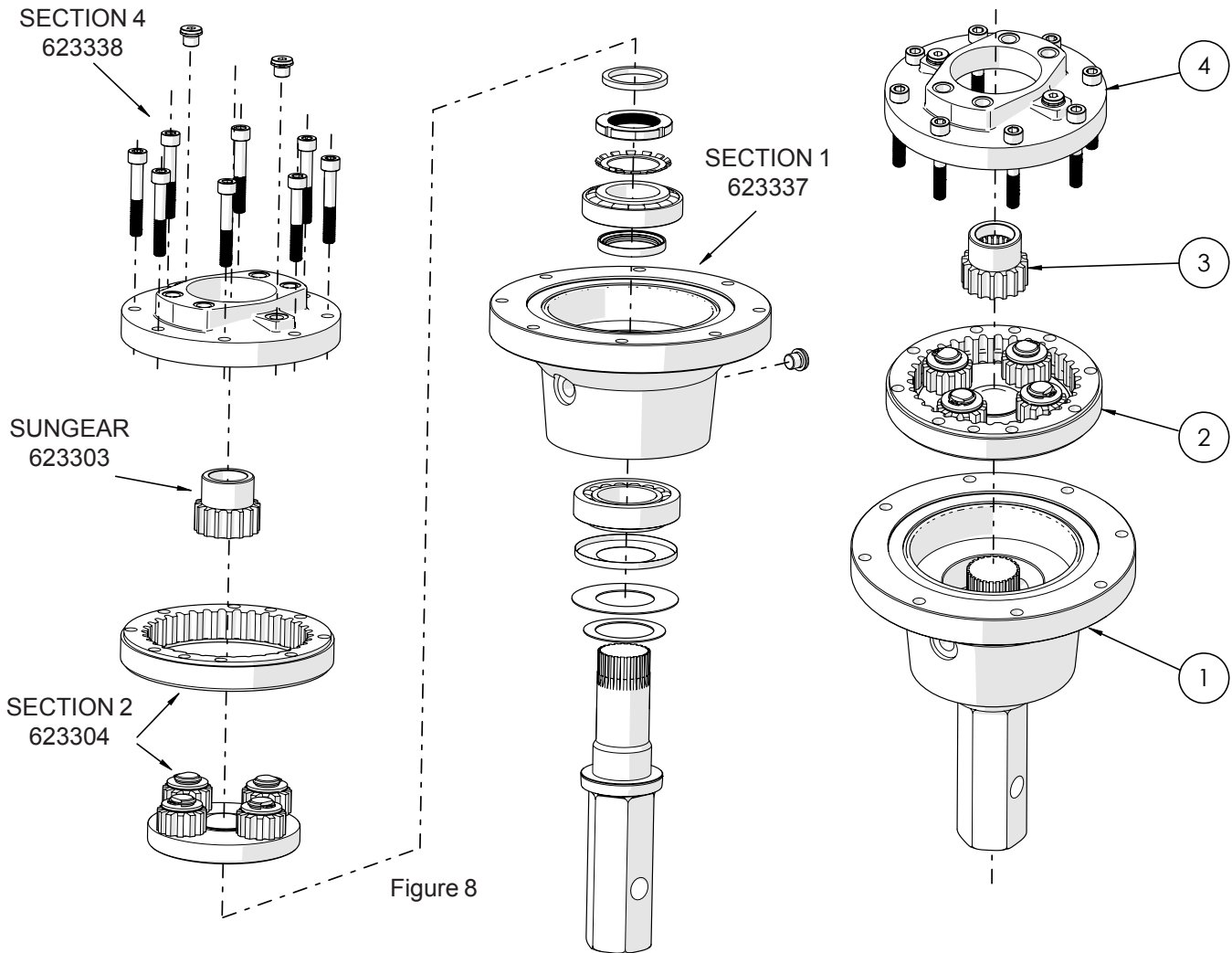

Figure 7

SA SERIES GEARBOX (623110) PARTS LIST

REPLACEMENT SEAL KIT INFORMATION

Part No.	Description
623330	SEAL KIT RE-241 (CS DRIVES)
623331	BEARING KIT RE-241(CS DRIVES)



GEARBOX REPLACEMENT PARTS

Replacement parts for the gearbox are sold as indicated by the exploded view drawing.

WARRANTY NOTICE

Any attempt to disassemble or make field repairs to the planetary gearbox will VOID the warranty. Please contact your dealer or distributor for further information.

ITEM	PART NO.	QTY.	DESCRIPTION
1	623337	1	OUTPUT SUP RE240 TEI3 (CH.2") CS GB (99554100)
2	623304	1	GEAR SET RE 240 N I=3.82 W/O SUNGEAR (99627500)
3	623303	1	SUNGEAR (12/24 DP z14) & BRNZ PAD (02982281)
4	623338	1	INPUT WHITE RS SAE-A CS GB (99627600)

SKID LOADER MOUNT (CB-SA) PARTS BREAKDOWN

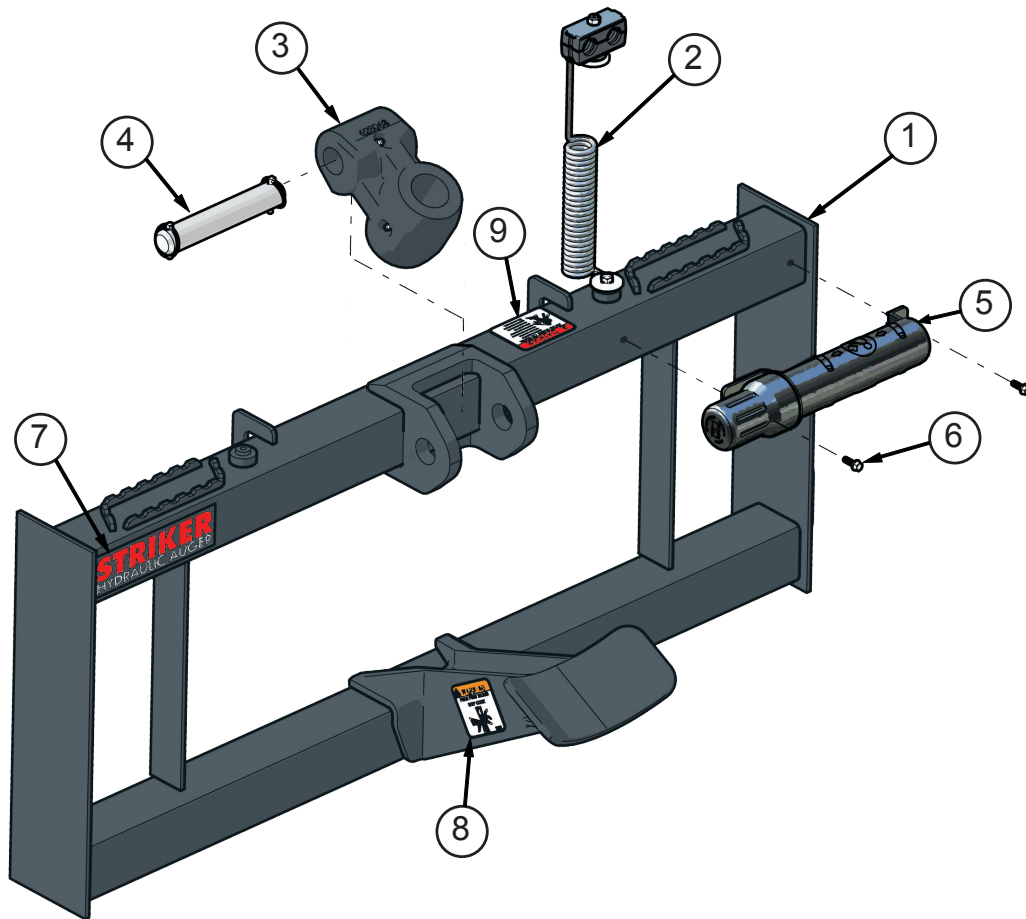

Figure 9

ITEM	PART No.	QTY	DESCRIPTION
1	623060	1	MOUNT ASSY SSL
2	661947	1	HOSE SPRING GUIDE
3	623064	1	KNUCKLE [CAST] 45 X 1-1/4 PAINT
4	623062	1	PIN SA SERIES
5	610000	1	MANUAL HOLDER
6	137444	2	SCREW 1/4"-20 SELF THREAD
7	350363	1	DECAL STRIKER DRIVE MOUNT
8	135502	2	DECAL PINCH POINT
9	350300	1	DECAL DANGER AUGER DRIVE

Please order replacement parts by PART NO. and DESCRIPTION.

BLANK PAGE

Please order replacement parts by PART NO. and DESCRIPTION.

WARRANTY POLICY

LIMITED WARRANTY

STRIKER, warrants its products against faulty design, material, and workmanship for the periods listed below. The warranty starts on the delivery date to the retail owner and is non-transferable.

WARRANTY PERIOD (Dating from the delivery to the original user)

Gearbox: 36 months or 750 operational hours, whichever occurs first.
Hyd. Motor: 36 months or 750 operational hours, whichever occurs first.

WARRANTY SERVICE

All new STRIKER products are warranted to be free from defects in material and workmanship, which may cause failure under normal usage and service when used for the purpose intended.

The STRIKER warranty covers faulty workmanship and defective parts manufactured by STRIKER. The warranty does not extend to transportation cost of parts nor does it cover consequential loss, damage to Hydraulic Hoses or ground engaging parts such as Sprockets, Digging Chain, Bearings and Teeth.

STRIKER Equipment must be operated in accordance with the recommended procedures and within the ranges as specified both on the Unit and contained in the Operating Manual.

Any claims under this warranty must be made within fourteen (14) days after the buyer learns of the facts upon which claim is based. All claims not made in writing and not received by STRIKER within the time specified above may be deemed waived. STRIKER will not be responsible for or accept any charges for work carried out by any repairs, or for any charges for any spare parts fitted to any STRIKER products without written approval from STRIKER. STRIKER's liability for any and all losses and damages to buyer resulting from any cause whatsoever, including STRIKER negligence irrespective of whether such defects are discoverable or latent, shall in no event exceed the purchase price of the particular parts, with respect to which losses or damages are claimed, or, at the discretion of STRIKER the repair or replacement of defective or damaged parts.

VOID WARRANTY

This warranty is void if field repairs or modifications have been made to the motor, gearbox and or controls without written approval. The complete unit must be available for inspection in it's original but alleged failed condition. This warranty does not apply to normal wear or to damage resulting from accident, abnormal use, abuse or neglect.

PRODUCT IMPROVEMENTS

Product improvement and modifications is an on going process at STRIKER. STRIKER reserves the right to make changes or additions to any product or to the warranty without incurring any obligations to make such changes available for previously sold products.

STRIKER makes no other warranty. All other warranties, whether expressed or implied, such as warranties of merchantability or fitness for a particular purpose, are hereby excluded and disclaimed to the extent that they exceed the warranties expressly granted in this limited warranty. In no event shall STRIKER be liable for consequential or incidental damages.

RETURNED GOODS POLICY





STRIKER reserves the right to determine whether products claimed to be defective shall be inspected by our personnel in the field or returned to the factory. If judged by STRIKER to be defective in material or workmanship, the product will be replaced or a credit issued at the option of STRIKER.

Upon notification of defect, STRIKER's Inside Sales Department will issue a Return Materials Authorization (RMA) number. All returns for replacement or credit MUST be accompanied by a RMA number. **Products returned without an RMA number will be rejected and returned to the sender freight collect.** All returns must be shipped "prepaid". Products shipped "collect" will be refused. Proof of purchase such as invoice number must accompany returns.

All RMA's must be returned within 30 days of the request.

TORQUE CHART FOR COMMON BOLT SIZES

The chart below lists the correct tightening torque for fasteners. When bolts are to be tightened or replaced, refer to this chart to determine the grade of the bolt and the proper torque. Except when specific torque values are list in a particular application.

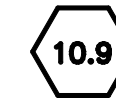
													
Bolt Size (In)	Grade 2		Grade 5		Grade 8		Bolt Size (mm)	Class 5.8		Class 8.8		Class 10.9	
tpi	Nm	Ft-Lbs	Nm	Ft-Lbs	Nm	Ft-Lbs	mm x	Nm	Ft-Lbs	Nm	Ft-Lbs	Nm	Ft-Lbs
1/4"-20	7.4	5.6	11	8	16	12	M5 X 0.8	4	3	6	5	9	7
1/4"-28	8.5	6	13	10	18	14	M6 X 1	7	5	11	8	15	11
5/16"-18	15	11	24	17	33	25	M8 X 1.25	17	12	26	19	36	27
5/16"-24	17	13	26	19	37	27	M8 X 1	18	13	28	21	39	29
3/8"-16	27	20	42	31	59	44	M10 X 1.5	33	24	52	39	72	53
3/8"-24	31	22	47	35	67	49	M10 X 0.75	39	29	61	45	85	62
7/16"-14	43	32	67	49	95	70	M12 X 1.75	58	42	91	67	125	93
7/16"-20	49	36	75	55	105	78	M12 X 1.5	60	44	95	70	130	97
1/2"-13	66	49	105	76	145	105	M12 X 1	90	66	105	77	145	105
1/2"-20	75	55	115	85	165	120	M14 X 2	92	68	145	105	200	150
9/16"-12	95	70	150	110	210	155	M14 X 1.5	99	73	155	115	215	160
9/16"-18	105	79	165	120	235	170	M16 X 2	145	105	225	165	315	230
5/8"-11	130	97	205	150	285	210	M16 X 1.5	155	115	240	180	335	245
5/8"-18	150	110	230	170	325	240	M18 X 2.5	195	145	310	230	405	300
3/4"-10	235	170	360	265	510	375	M18 X 1.5	220	165	350	260	485	355
3/4"-16	260	190	405	295	570	420	M20 X 2.5	280	205	440	325	610	450
7/8"-9	225	165	585	430	820	605	M20 X 1.5	310	230	650	480	900	665
7/8"-14	250	185	640	475	905	670	M24 X 3	480	355	760	560	1050	780
1"-8	340	250	875	645	1230	910	M24 X 2	525	390	830	610	1150	845
1"-12	370	275	955	705	1350	995	M30 X 3.5	960	705	1510	1120	2100	1550
1-1/8"-7	480	355	1080	795	1750	1290	M30 X 2	1060	785	1680	1240	2320	1710
1-1/8"-12	540	395	1210	890	1960	1440	M36 X 3.5	1730	1270	2650	1950	3660	2700
1-1/4"-7	680	500	1520	1120	2460	1820	M36 X 2	1880	1380	2960	2190	4100	3220
1-1/4"-12	750	555	1680	1240	2730	2010							
1-3/8"-6	890	655	1990	1470	3230	2380							
1-3/8"-12	1010	745	2270	1670	3680	2710							
1-1/2"-6	1180	870	2640	1950	4290	3160							
1-1/2"-12	1330	980	2970	2190	4820	3560							

tpi = Nominal thread diameter in inches per inch.

Nm = Newton Meters.

Ft-Lbs = Foot Pounds

mm x = Nominal thread diameter in millimeters x thread pitch.

STRIKER
HYDRAULIC AUGERS

TOKU 
AMERICA inc.

Toku America Inc.

3900 Ben Hur Ave #3
Wiloughby, OH 44094
PH: 877-954-9923

www.toku-america.com



**Know what's below.
Call before you dig.**

Printed in the USA