

OPERATION MANUAL



***ESSICK* SERIES MODELS**

PRO12/PRO12E51

PRO12E53/PRO12E53-460V

HYDRAULIC PLASTER/MORTAR MIXERS

**(HONDA GX390RT2-QNB2 GASOLINE ENGINE/
TECO WESTINGHOUSE 5HP ELECTRIC MOTOR)**

Revision #4 (10/30/19)

To find the latest revision of this publication or
associated parts manual, visit our website at:
www.multiquip.com



THIS MANUAL MUST ACCOMPANY THE EQUIPMENT AT ALL TIMES.

PROPOSITION 65 WARNING



SILICOSIS/RESPIRATORY WARNINGS

! WARNING



SILICOSIS WARNING

Grinding/cutting/drilling of masonry, concrete, metal and other materials with silica in their composition may give off dust or mists containing crystalline silica. Silica is a basic component of sand, quartz, brick clay, granite and numerous other minerals and rocks. Repeated and/or substantial inhalation of airborne crystalline silica can cause serious or fatal respiratory diseases, including silicosis. In addition, California and some other authorities have listed respirable crystalline silica as a substance known to cause cancer. When cutting such materials, always follow the respiratory precautions mentioned above.

! WARNING



RESPIRATORY HAZARDS

Grinding/cutting/drilling of masonry, concrete, metal and other materials can generate dust, mists and fumes containing chemicals known to cause serious or fatal injury or illness, such as respiratory disease, cancer, birth defects or other reproductive harm. If you are unfamiliar with the risks associated with the particular process and/or material being cut or the composition of the tool being used, review the material safety data sheet and/or consult your employer, the material manufacturer/supplier, governmental agencies such as OSHA and NIOSH and other sources on hazardous materials. California and some other authorities, for instance, have published lists of substances known to cause cancer, reproductive toxicity, or other harmful effects.

Control dust, mist and fumes at the source where possible. In this regard use good work practices and follow the recommendations of the manufacturers or suppliers, OSHA/NIOSH, and occupational and trade associations. Water should be used for dust suppression when wet cutting is feasible. When the hazards from inhalation of dust, mists and fumes cannot be eliminated, the operator and any bystanders should always wear a respirator approved by NIOSH/MSHA for the materials being used.

PRO12 Hydraulic Mixer

| | |
|--|-------|
| Proposition 65 Warning | 2 |
| Silicosis/Respiratory Warnings | 3 |
| Table of Contents..... | 4 |
| Safety Information | 6–10 |
| Specifications | 11 |
| Dimensions..... | 12 |
| General Information..... | 13 |
| Components (Mixer) | 14–15 |
| Components (Engine)..... | 16 |
| Electric Motor | 17 |
| Inspection | 18–20 |
| Paddle Blade Adjustment | 21 |
| Operation..... | 22–26 |
| Maintenance | 27–29 |
| Troubleshooting (Engine)..... | 31–32 |
| Troubleshooting (Motor)..... | 33 |
| Troubleshooting (Mixer) | 34 |
| Hydraulic Hose Connections | 35 |
| Hydraulic System Locator..... | 36 |
| Hydraulic System Diagram | 37 |
| Electric Motor (Single Phase) Wiring Diagram | 38 |
| Electric Motor (Three Phase) Wiring Diagram..... | 39 |

NOTICE

Specifications and part numbers are subject to change without notice.

SAFETY INFORMATION

Do not operate or service the equipment before reading the entire manual. Safety precautions should be followed at all times when operating this equipment. Failure to read and understand the safety messages and operating instructions could result in injury to yourself and others.



SAFETY MESSAGES

The four safety messages shown below will inform you about potential hazards that could injure you or others. The safety messages specifically address the level of exposure to the operator and are preceded by one of four words: **DANGER**, **WARNING**, **CAUTION** or **NOTICE**.

SAFETY SYMBOLS

! DANGER

Indicates a hazardous situation which, if not avoided, **WILL** result in **DEATH** or **SERIOUS INJURY**.

! WARNING

Indicates a hazardous situation which, if not avoided, **COULD** result in **DEATH** or **SERIOUS INJURY**.





! CAUTION

Indicates a hazardous situation which, if not avoided, **COULD** result in **MINOR** or **MODERATE INJURY**.

NOTICE

Addresses practices not related to personal injury.

Potential hazards associated with the operation of this equipment will be referenced with hazard symbols which may appear throughout this manual in conjunction with safety messages.

| Symbol | Safety Hazard |
|--|----------------------------|
|  | Lethal exhaust gas hazards |
|  | Explosive fuel hazards |
|  | Burn hazards |
|  | Rotating parts hazards |

SAFETY INFORMATION

GENERAL SAFETY

CAUTION

- **NEVER** operate this equipment without proper protective clothing, shatterproof glasses, respiratory protection, hearing protection, steel-toed boots and other protective devices required by the job or city and state regulations.



- Avoid wearing jewelry or loose fitting clothes that may snag on the controls or moving parts as this can cause serious injury.
- **NEVER** operate this equipment when not feeling well due to fatigue, illness or when under medication.
- **NEVER** operate this equipment under the influence of drugs or alcohol.



- **ALWAYS** clear the work area of any debris, tools, etc. that would constitute a hazard while the equipment is in operation.
- **ALWAYS** check the equipment for loosened threads or bolts before starting.
- **DO NOT** use the equipment for any purpose other than its intended purposes or applications.

NOTICE

- This equipment should only be operated by trained and qualified personnel 18 years of age and older.
- Whenever necessary, replace nameplate, operation and safety decals when they become difficult read.
- Manufacturer does not assume responsibility for any accident due to equipment modifications. Unauthorized equipment modification will void all warranties.
- **NEVER** use accessories or attachments that are not recommended by Multiquip for this equipment. Damage to the equipment and/or injury to user may result.
- **ALWAYS** know the location of the nearest fire extinguisher.
- **ALWAYS** know the location of the nearest first aid kit.
- **ALWAYS** know the location of the nearest phone or **keep a phone on the job site**. Also, know the phone numbers of the nearest **ambulance, doctor and fire department**. This information will be invaluable in the case of an emergency.



SAFETY INFORMATION

MIXER SAFETY

DANGER

- **NEVER** operate the equipment in an explosive atmosphere or near combustible materials. An explosion or fire could result causing severe **bodily harm or even death.**



- **DO NOT** mix **flammable** or **explosive** substances.

WARNING

- **NEVER** place your hands inside the drum while starting or operating this equipment.
- **NEVER** disconnect any **emergency or safety devices.** These devices are intended for operator safety. Disconnection of these devices can cause severe injury, bodily harm or even death. Disconnection of any of these devices will void all warranties.



- Before operating mixer, ensure that safety grate is in position and correctly fitted.

CAUTION

- **NEVER** lubricate components or attempt service on a running machine.

NOTICE

- **ALWAYS** keep the machine in proper running condition.
- **ALWAYS** ensure mixer is on level ground before mixing.
- Fix damage to machine and replace any broken parts immediately.
- **DO NOT** tip mixer onto drum mouth when the drum is rotating.
- Ensure the drum is rotating while filling and emptying the drum.
- **ALWAYS** store equipment properly when it is not being used. Equipment should be stored in a clean, dry location out of the reach of children and unauthorized personnel.
- **ALWAYS** deploy stabilizer jack stands prior to use.

ENGINE SAFETY (GASOLINE MODELS ONLY)

DANGER

- Engine fuel exhaust gases contain poisonous carbon monoxide. This gas is colorless and odorless, and can cause death if inhaled.
- The engine of this equipment requires an adequate free flow of cooling air. **NEVER** operate this equipment in any enclosed or narrow area where free flow of the air is restricted. If the air flow is restricted it will cause injury to people and property and serious damage to the equipment or engine.



WARNING

- **DO NOT** place hands or fingers inside engine compartment when engine is running.
- **NEVER** operate the engine with heat shields or guards removed.
- Keep fingers, hands hair and clothing away from all moving parts to prevent injury.
- **DO NOT** remove the engine oil drain plug while the engine is hot. Hot oil will gush out of the oil tank and severely scald any persons in the general area of the mixer.



CAUTION

- **NEVER** touch the hot exhaust manifold, muffler or cylinder. Allow these parts to cool before servicing equipment.
- Make certain the operator knows how to and is capable of turning the engine OFF in case of an emergency.



NOTICE

- **NEVER** run engine without an air filter or with a dirty air filter. Severe engine damage may occur. Service air filter frequently to prevent engine malfunction.
- **NEVER** tamper with the factory settings of the engine or engine governor. Damage to the engine or equipment can result if operating in speed ranges above the maximum allowable.



SAFETY INFORMATION

FUEL SAFETY (GASOLINE MODELS ONLY)

DANGER

- **DO NOT** add fuel to equipment if it is placed inside truck bed with plastic liner. Possibility exists of explosion or fire due to static electricity.

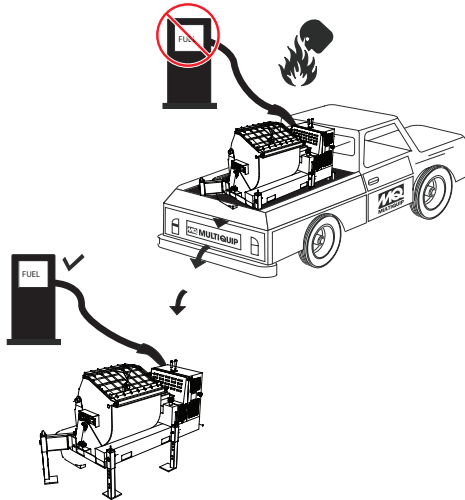

- **DO NOT** start the engine near spilled fuel or combustible fluids. Fuel is extremely flammable and its vapors can cause an explosion if ignited.
- **ALWAYS** refuel in a well-ventilated area, away from sparks and open flames.
- **ALWAYS** use extreme caution when working with **flammable** liquids.
- **DO NOT** fill the fuel tank while the engine is running or hot.
- **DO NOT** overfill tank, since spilled fuel could ignite if it comes into contact with hot engine parts or sparks from the ignition system.
- Store fuel in appropriate containers, in well-ventilated areas and away from sparks and flames.
- **NEVER** use fuel as a cleaning agent.
- **DO NOT** smoke around or near the equipment. Fire or explosion could result from fuel vapors or if fuel is spilled on a hot engine.



GENERATOR SAFETY

If using a generator to power mixer, refer to applicable generator manual safety information section.



ELECTRIC MOTOR SAFETY (ELECTRIC MODELS ONLY)

NOTICE

- Operate electric motor only at the specified voltage indicated on the nameplate.
- **DO NOT** spray water onto electric motor.
- **ALWAYS** disconnect AC power plug from power source before moving mixer.
- **ALWAYS** make sure the ON/OFF switch on the electric motor is in the OFF position when not in use and before inserting the mixer's power plug into an AC receptacle.



Power Cord/Cable Safety

DANGER

- **NEVER** let power cords or cables **lay in water**.
- **NEVER** use **damaged** or **worn** cables or cords when connecting equipment to generator. Inspect for cuts in the insulation.
- **NEVER** grab or touch a live power cord or cable with wet hands. The possibility exists of **electrical shock, electrocution or death**.
- Make sure power cables are securely connected. Incorrect connections may cause electrical shock and damage to the mixer.

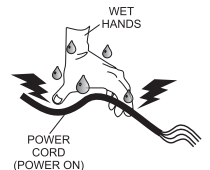

CAUTION

- Ensure that cables and cords will not be tripped over or trapped underneath the mixer.

NOTICE

- **ALWAYS** make certain that proper power or extension cord has been selected for the job.

SAFETY INFORMATION

TRANSPORTING SAFETY

CAUTION

- **NEVER** allow any person or animal to stand underneath the equipment while lifting.

NOTICE

- **ALWAYS** make sure forklift forks are inserted into pockets (if applicable) as far as possible when lifting the mixer.
- **ALWAYS** shutdown engine before transporting.
- **NEVER** lift the equipment while the engine is running.
- Tighten fuel tank cap securely and close fuel cock to prevent fuel from spilling.
- **DO NOT** lift machine to unnecessary heights.
- **ALWAYS** tie down equipment during transport by securing the equipment with rope.
- **NEVER** tip the engine to extreme angles during lifting as it may cause oil to gravitate into the cylinder head, making the engine start difficult.

ENVIRONMENTAL SAFETY/DECOMMISSIONING

NOTICE

Decommissioning is a controlled process used to safely retire a piece of equipment that is no longer serviceable. If the equipment poses an unacceptable and unrepairable safety risk due to wear or damage or is no longer cost effective to maintain (beyond life-cycle reliability) and is to be decommissioned (demolition and dismantlement), be sure to follow rules below.

- **DO NOT** pour waste or oil directly onto the ground, down a drain or into any water source.
- Contact your country's Department of Public Works or recycling agency in your area and arrange for proper disposal of any electrical components, waste or oil associated with this equipment.



- When the life cycle of this equipment is over, remove battery if equipped and bring to appropriate facility for lead reclamation. Use safety precautions when handling batteries that contain sulfuric acid.

- When the life cycle of this equipment is over, it is recommended that the mixer frame and all other metal parts be sent to a recycling center.

Metal recycling involves the collection of metal from discarded products and its transformation into raw materials to use in manufacturing a new product.

Recyclers and manufacturers alike promote the process of recycling metal. Using a metal recycling center promotes energy cost savings.

EMISSIONS INFORMATION

NOTICE

The gasoline engine used in this equipment has been designed to reduce harmful levels of carbon monoxide (CO), hydrocarbons (HC) and nitrogen oxides (NOx) contained in gasoline exhaust emissions.

This engine has been certified to meet US EPA Evaporative emissions requirements in the installed configuration.

Attempting to modify or make adjustments to the engine emission system by unauthorized personnel without proper training could damage the equipment or create an unsafe condition.

Additionally, modifying the fuel system may adversely affect evaporative emissions, resulting in fines or other penalties.

Emission Control Label

The emission control label is an integral part of the emission system and is strictly controlled by regulation(s).

The label must remain with the engine for its entire life.

If a replacement emission label is needed, please contact your authorized engine distributor.

| Table 1. Mixer Specifications | |
|--------------------------------------|-----------------------------|
| Capacity | 12.0 cu. ft. (340 liters) |
| Bag Capacity | 3 to 4 bags |
| Operating Weight | 1,580 lb. (716.67 kg) |
| Maximum Aggregate Size | 1 in. (25.4 mm) |
| Adjustable Drum Discharge Height | Up to 42.5 in. (1,079.5 mm) |
| Drive System | Hydraulic |
| Dump Action | Hydraulic |

| Table 2. Engine Specifications | |
|---------------------------------------|---|
| Model | Honda GX390RT2-QNB2 |
| Type | Air-cooled, 4-stroke, horizontal-shaft, gasoline engine |
| Bore x Stroke | 3.46 in. x 2.51 in. (88 mm x 64 mm) |
| Displacement | 23.7 cu. in. (389 cc) |
| Max. Output | 11.7 hp @ 3,600 rpm |
| Continuous Output | 9.0 hp @ 3,600 rpm |
| Fuel Tank Capacity | Approx. 5.0 U.S. gallons (18.9 liters) |
| Fuel | Unleaded gasoline |
| Lube Oil Capacity | 1.16 qt. (1.1 liters) |
| Speed Control Method | Centrifugal fly-weight type |
| Starting Method | Electric start |

| Table 3. Electric Motor Specifications | | |
|---|--|--|
| Model | Teco Westinghouse Model 3414 | Teco Westinghouse Model 3481 |
| Enclosure | TEFC | TEFC |
| Horsepower | 5 | 5 |
| Input Voltage (VAC) | 230 | 230/460 |
| Phase | 1 | 3 |
| Frequency (Hz) | 60 | 60 |
| Max Output @ RPM | 5 hp @ 1,745 | 5 hp @ 1,725 |
| Full Load Amps | 30 | 12.24/6.12 |
| Weight | 103 lb. (46.7 kg) | 103 lb. (46.7 kg) |
| Dimensions (L x W x H) | 18.03 x 8.8 x 10.5 in. (458 x 223.5 x 266.7 mm) | 15.79 x 8.8 x 10.5 in. (401 x 223.5 x 266.7 mm) |

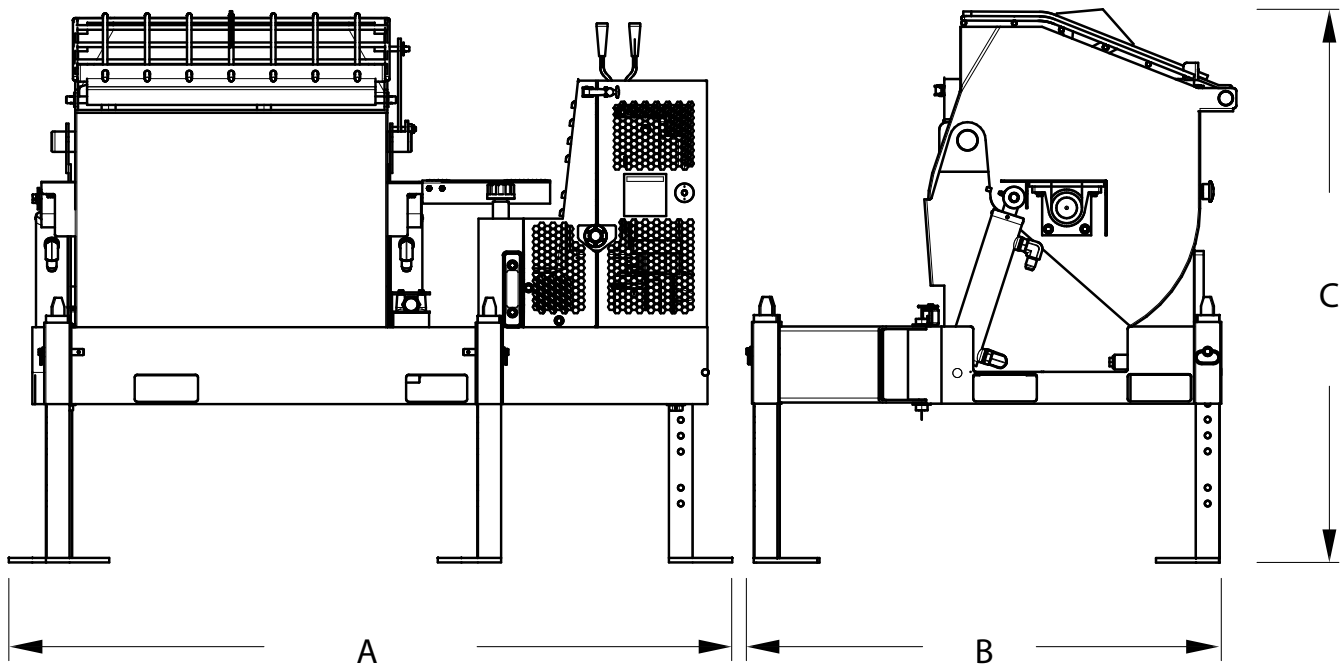

Figure 1. Mixer Dimensions

| Table 4. Mixer Dimensions | |
|---------------------------|---------------------|
| Reference Designator | Dimension in. (mm.) |
| A (Length) | 73.5 (1,917.7) |
| B (Width) | 35.0 (889) |
| C (Height) | 45.0 (1,143) |

APPLICATION

The Multiquip PRO12 hydraulic mixer (with drum capacity of 12.0 cubic feet/340 liters) is shipped completely assembled, factory tested, and ready for use. This mixer has a batch capacity of 3-1/2 to 4-1/2 bags.

WARNING

This mixer is intended **only** for the mixing of plaster and mortar. The mixer must be used for its intended purpose and **is not suitable for mixing flammable or explosive substances. The mixer must not be used in an explosive atmosphere.**

POWER PLANTS

This hydraulic mixer is powered by either an 11.7 hp Honda GX390RT2-QNB2 air-cooled, 4-stroke, gasoline engine (reference Table 2), or a 5 hp electric motor. Reference Table 3 for more detailed information regarding the electric motor.

ENGINE MAINTENANCE

For basic engine maintenance, refer to the engine maintenance section in this manual. For more detailed engine maintenance, refer to the Honda Engine Owner's Manual furnished with the engine.

ELECTRICAL

If the mixer is equipped with an electric motor, make sure that the power being supplied to the motor corresponds to the voltage rating label on the motor. Supplying the wrong voltage to the electric motor will cause severe electrical damage to the motor. Reference Table 3 for electric motor specifications.

Always make sure the **ON/OFF** switch on the electric motor is in the **OFF** position before applying power.

EXTENSION CABLES

The extension cable should be a 3-wire configuration that includes a ground wire that conforms to UL code. The wire cross section must be a minimum of 2.5 mm². Choose an extension cord of adequate current-carrying capacity as referenced in Table 7. Remember, **cable distance** affects the current-voltage capacity of the extension cable.

Ensure that the extension cable is carefully laid out avoiding **wet areas, sharp edges**, and locations where vehicles might run over it. Avoid allowing the extension cable to be trapped underneath the mixer.

Unroll the extension cable fully or it will overheat and could catch fire. Make sure that all extension cable connections are dry and safe. Replace any defective or badly worn extension cables immediately.

HARDWARE

Check all hardware on the mixer before starting. Periodically inspect all hardware. Loose hardware can contribute to early component failure and poor performance. Keep all mixer hardware components tight.

COMPONENTS (MIXER)

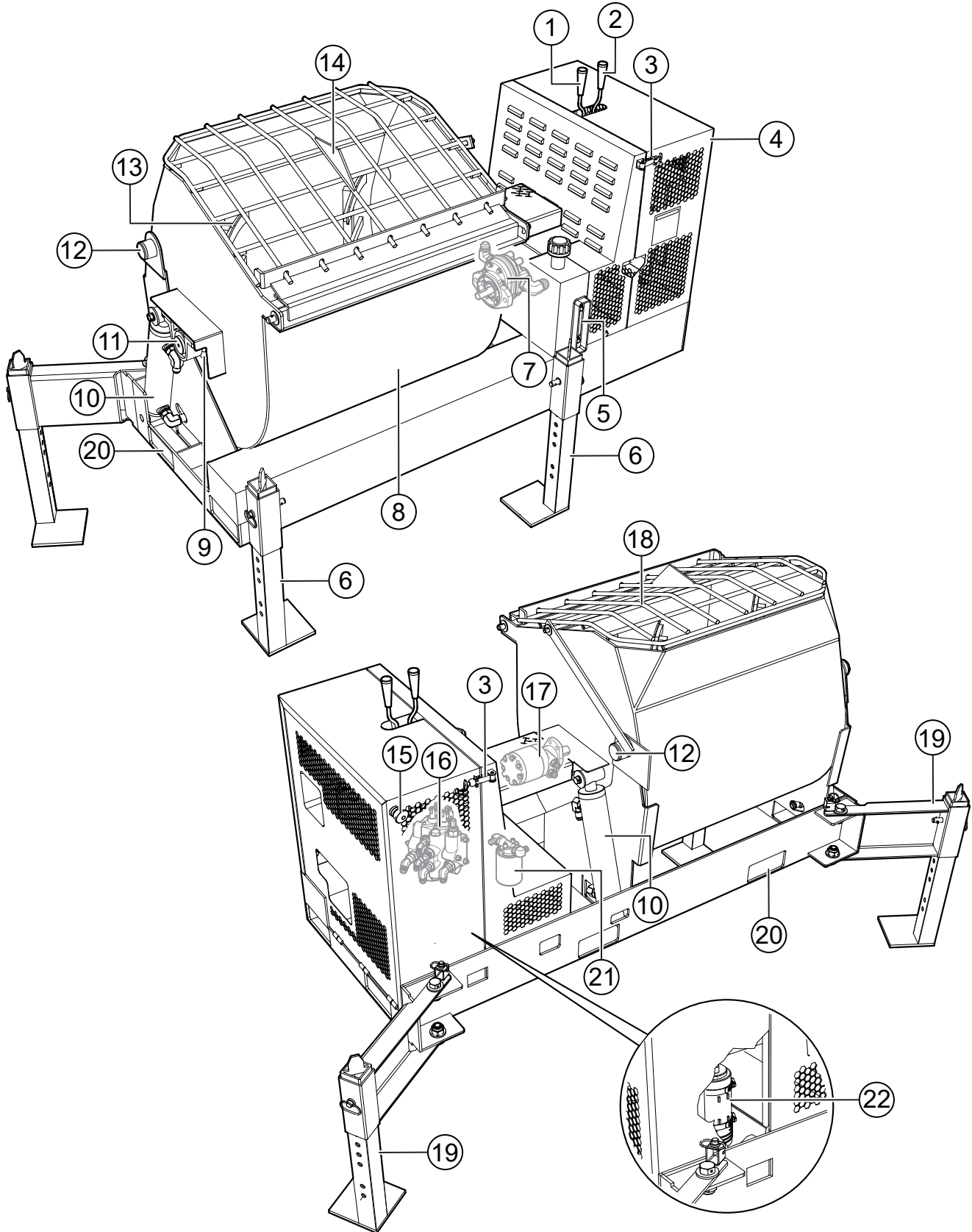

Figure 2. Mixer Components

COMPONENTS (MIXER)

1. **Hydraulic Paddle Control Lever** — 3-position lever. Push inward for clockwise mixing rotation of blades. Place in center position for no rotation (neutral/off).
2. **Hydraulic Dump Lever** — This lever is only provided on mixers with hydraulic dump capability. Pull the lever outward to activate the dump cylinder.
3. **Latch** — Use this latch to secure the engine compartment enclosure.
4. **Engine Cover** — Lift this cover to gain access to the engine or electric motor.
5. **Hydraulic Oil Sight Gauge** — This gauge indicates the level and temperature of the hydraulic oil. For normal operation, the oil level should be visible at the midpoint on the sight gauge.
6. **Adjustable Stabilizer Jack Stands** — Use these jack stands to adjust the mixer to the desired height.
7. **Hydraulic Pump** — Supplies hydraulic fluid to the hydraulic control valve.
8. **Mixing Drum** — Drum capacity is 12 cubic feet (340 liters). Mixing materials such as mortar and plaster are to be placed into this drum for mixing. Always clean the drum after each use.
9. **Shaft Seals** — There is a Zerk grease fitting at each end of the mixing drum. These grease fittings lubricate the paddle shaft seals. Fittings require daily greasing with lithium-based EP grease.
10. **Hydraulic Dump Cylinders** — When activated, these cylinders will rotate the mixing drum to the dump position. These cylinders are equipped on mixers with hydraulic dump capability.
11. **Drum Bearing** — There is a pillow block bearing on each end of the mixing drum. Bearings require daily greasing with lithium-based EP grease.
12. **Pivot Point/Zerk Fitting** — There is a Zerk grease fitting on each end of the mixing drum. These fittings lubricate the dumping mechanism. Lubricate both fittings at least twice a week.
13. **Mixing Paddles** — This mixer uses plastic and rubber mixing paddles for the mixing of plaster and mortar. Always clean the paddles after each use.
14. **Bag Cutter** — This feature allows mixing bags to be opened easily, therefore allowing the contents of the bag to fall directly into the mixing drum.
15. **Emergency Stop Switch** — This switch is located on the side of the engine cover. When activated it will shut down the engine (gasoline only).
16. **Hydraulic Valve** — Directional hydraulic control valve. Controls the direction of hydraulic fluid supplied to the dump cylinder and paddle shaft.
17. **Hydraulic Motor** — Bidirectional hydraulic motor that is used in conjunction with the directional control valve to operate the hydraulic dump cylinder and paddle shaft.
18. **Safety Grill** — Provided for operator safety. This safety grill is designed to keep hands and solid objects out of the mixing drum when in use. This grill should be closed at all times when the mixer is in use. **DO NOT** remove the grill or grill opening bar. Keep the grill clean by washing it down daily.
19. **Swivel Jack Stands** — These jack stands swivel out to support the mixer.
20. **Forklift Pockets** — When lifting of the mixer is required, use these forklift pockets to lift the mixer. Remember to insert the forks of the forklift a minimum of 24 inches into the lift pockets.
21. **Hydraulic Oil Filter** — 10-micron hydraulic filter. Filters out small particles that are harmful to the hydraulic system.
22. **Charcoal Canister** — A container filled with activated charcoal traps gasoline vapors emitted by the fuel system (gasoline only).

COMPONENTS (ENGINE)

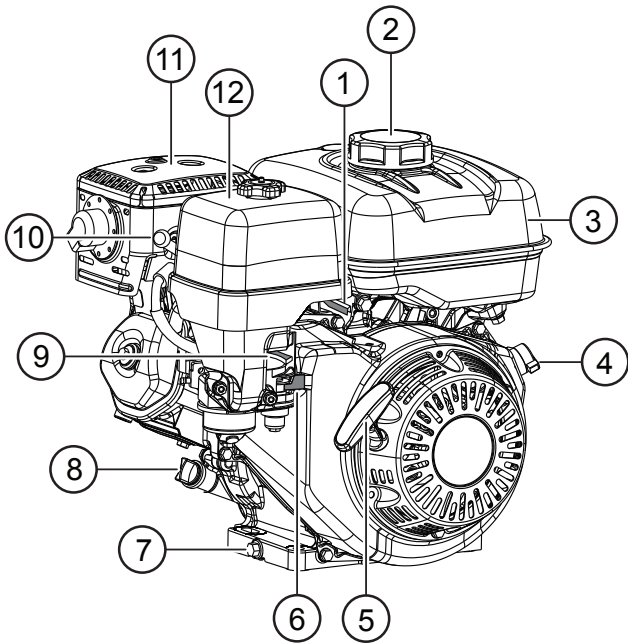

Figure 3. Engine Components

INITIAL SERVICING

The engine (Figure 3) must be checked for proper lubrication and filled with fuel prior to operation. Refer to the engine manufacturer's manual for instructions and details on operation and servicing.

1. **Throttle Lever** — Use to adjust engine RPM speed (lever advanced forward **SLOW**, lever back toward operator **FAST**).
2. **Fuel Filler Cap** — Remove this cap to add unleaded gasoline to the fuel tank. Make sure the cap is tightened securely. **DO NOT** overfill.

DANGER



Adding fuel to the tank should be done only when the engine is stopped and has had an opportunity to cool down. In the event of a fuel spill, **DO NOT** attempt to start the engine until the fuel residue has been completely wiped up, and the area surrounding the engine is dry.

3. **Fuel Tank** — Holds unleaded gasoline. For additional information refer to the engine owner's manual.

4. **Engine ON/OFF Switch** — **ON** position permits engine starting, **OFF** position stops engine operation.
5. **Recoil Starter (pull rope)** — Manual starting method. Pull the starter grip slowly until resistance is felt, then pull briskly and smoothly to start the engine.
6. **Fuel Valve Lever** — **OPEN** to let fuel flow, **CLOSE** to stop the flow of fuel.
7. **Oil Drain Bolt** — Remove to drain engine oil from the crankcase.
8. **Oil Dipstick** — Remove to check the amount and condition of oil in the crankcase.
9. **Choke Lever** — Used in the starting of a cold engine, or in cold weather conditions. The choke enriches the fuel mixture.
10. **Spark Plug** — Provides spark to the ignition system. Set the spark plug gap to 0.028–0.031 inch (0.7–0.8 mm). Clean the spark plug once a week.
11. **Muffler** — Reduces noise and emissions.

WARNING



Engine components can generate extreme heat. To prevent burns, **DO NOT** touch these areas while the engine is running or immediately after operating. **NEVER** operate the engine with the muffler removed.

12. **Air Cleaner** — Prevents dirt and other debris from entering the fuel system. Remove the wing nut on top of the air filter canister to gain access to the filter element.

NOTICE

Operating the engine without an air filter, with a damaged air filter, or with a filter in need of replacement will allow dirt to enter the engine, causing rapid engine wear.

ELECTRIC MOTOR

ELECTRIC MOTOR

For operation and maintenance of the electric motor, refer to the electric motor instruction booklet furnished with the motor.

Protect the electric motor from dust as much as possible and keep ventilating openings clean.

CAUTION

DO NOT spray water at any time on the electric motor.

DO NOT operate the electric motor in an explosive environment.

The electric motor (Figure 4) equipped on these mixers is available in two configurations—5 hp, 1Ø @ 230 VAC or 5 hp, 3Ø @ 230/460 VAC. Pay special attention to the nameplate on the electric motor when supplying power to the electric motor. Applying incorrect power to the motor can severely damage the motor and **may cause serious bodily injury!**

ALWAYS make certain that the correct voltage is being supplied to the motor. The input voltage requirements can be found on the electric motor's nameplate.

ELECTRIC MOTOR POWER CONNECTIONS

The electric motor used on these mixers is equipped with either a 3-prong (1Ø) or a 4-prong (3Ø) plug. Reference Figure 4 for connection to a power source. Reference Table 5 to determine the required NEMA mating receptacle.

NOTICE

It is strongly recommended that all electrical wiring be done by a **licensed electrician**. Pay special attention to the nameplate on the electric motor. Make certain that the voltage supplied to the electric motor matches the required operating voltage printed on the nameplate.

Table 5. Electric Motor Wiring Information

| Electric Motor Horsepower Rating | 230 VAC - 1Ø | 230/460 VAC - 3Ø |
|----------------------------------|--|--|
| 5 hp | NEMA Plug Connector 3-Prong L6-30P | NEMA Plug Connector 4-Prong L15-30P L16-30P |
| | NEMA Receptacle Connector 3-Prong L6-30R | NEMA Receptacle Connector 4-Prong L15-30R L16-30R |

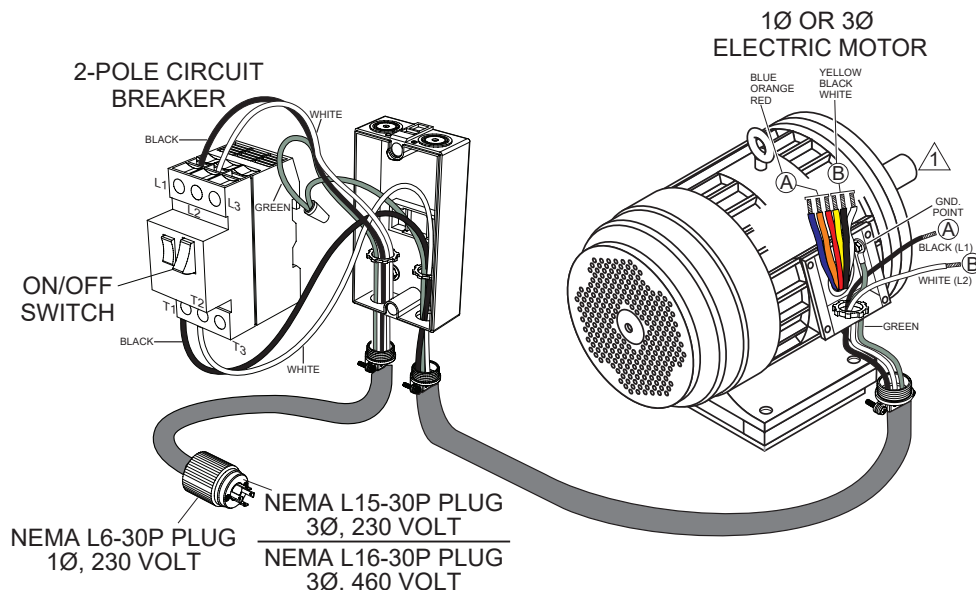

Figure 4. Electric Motor

BEFORE STARTING

1. Read the safety instructions at the beginning of this manual.
2. Clean the mixer, removing dirt and dust—particularly the engine cooling air inlet, carburetor, and air cleaner.
3. Check the air filter for dirt and dust. If the air filter is dirty, replace it with a new one as required.
4. Check the carburetor for external dirt and dust. Clean with dry compressed air.
5. Check fastening nuts and bolts for tightness.



ENGINE OIL CHECK

1. Place the mixer on secure, level ground with the engine stopped.
2. Remove the filler dipstick from the engine oil filler hole (Figure 5) and wipe it clean.

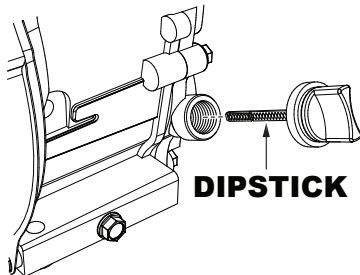

Figure 5. Engine Oil Dipstick (Removal)

3. Insert and remove the dipstick without screwing it into the filler neck. Check the oil level shown on the dipstick.
4. If the oil level is low (See Figure 6), fill to the edge of the oil filler hole with the recommended oil type as listed in Table 6. Maximum oil capacity is 1.16 quarts (1.1 liters).

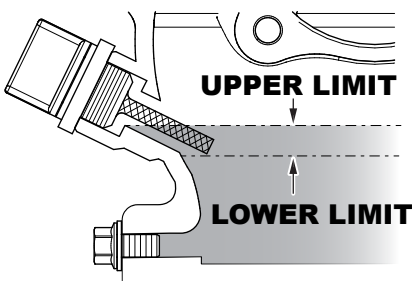

Figure 6. Engine Oil Dipstick (Oil Level)

Table 6. Oil Type

| Season | Temperature | Oil Type |
|-------------|----------------|---------------|
| Summer | 25°C or Higher | SAE 10W-30 |
| Spring/Fall | 25°C–10°C | SAE 10W-30/20 |
| Winter | 0°C or Lower | SAE 10W-10 |

FUEL CHECK

! DANGER



Motor fuels are highly flammable and can be dangerous if mishandled. **DO NOT** smoke while refueling. **DO NOT** attempt to refuel the pump if the engine is **hot!** or running.

1. Remove the gasoline cap located on top of the fuel tank.
2. Visually inspect to see if the fuel level is low. If fuel is low, replenish with unleaded gasoline.
3. When refueling, be sure to use a strainer for filtration. **DO NOT** top off fuel. Wipe up any spilled fuel **immediately!**

HYDRAULIC OIL

Check the hydraulic oil sight gauge (Figure 7) to ensure that the hydraulic oil is at the midway level.



Figure 7. Hydraulic Oil Sight Gauge

HYDRAULIC HOSES

Check hydraulic hoses to make sure they are not worn, frayed or defective.

GREASE FITTINGS (SHAFT SEALS)

Check the Zerk grease fittings (Figure 8) at each end of the mixing drum. These grease fittings lubricate the paddle shaft seals. Grease daily with lithium-based EP grease, preferably at the end of the day. Grease until visible inside the drum to ensure that the cavity area is free of contamination.

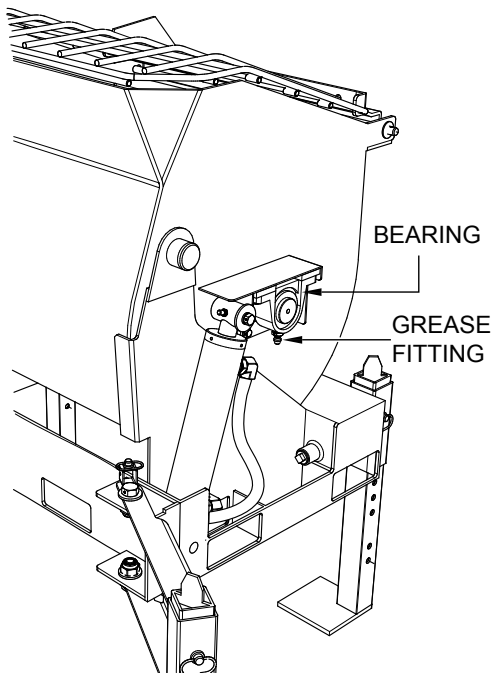

Figure 8. Grease Fittings (Bearings and Seals)

GREASE FITTINGS (BEARINGS)

Check the Zerk fittings on the pillow block bearings (Figure 8). Grease with two shots of lithium-based EP grease daily.

GREASE FITTINGS (DUMP CYLINDERS)

Check the Zerk grease fittings on the dump cylinders (Figure 9). These grease fittings lubricate the hydraulic dumping mechanism. Give the fittings one shot of lithium-based EP grease every week.

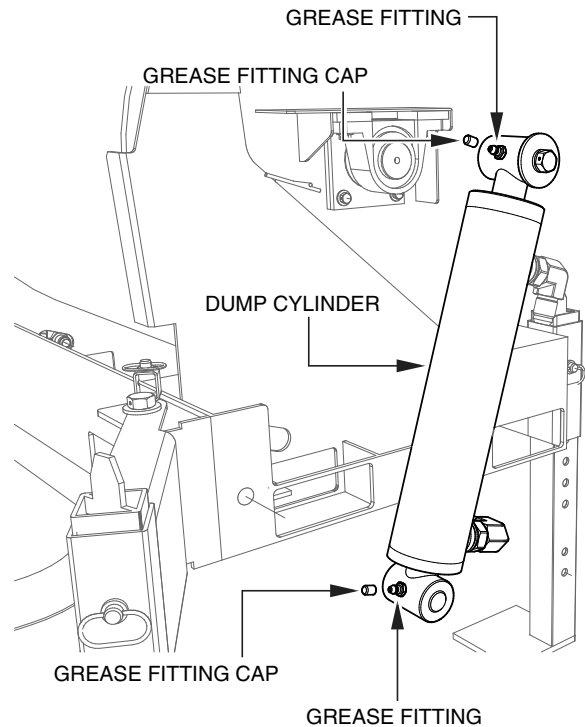

Figure 9. Grease Fittings (Dump Cylinders)

EMERGENCY STOP SWITCH (GASOLINE ENGINE MODELS ONLY)

The engine **emergency stop switch** (Figure 10) should be tested every time the engine is started. See **Starting the Mixer (Gasoline Engine)** in the **Operation** section for more information.

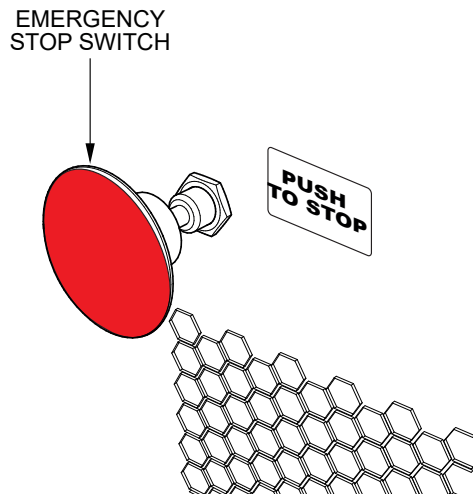

Figure 10. Emergency Stop Switch

PADDLE BLADE CHECK

Check for **worn or defective** paddle blades (Figure 11). Make sure that all blades are adjusted properly. Refer to the **Paddle Blade Adjustment** procedure (Figure 12). Replace all defective or damaged blades immediately.

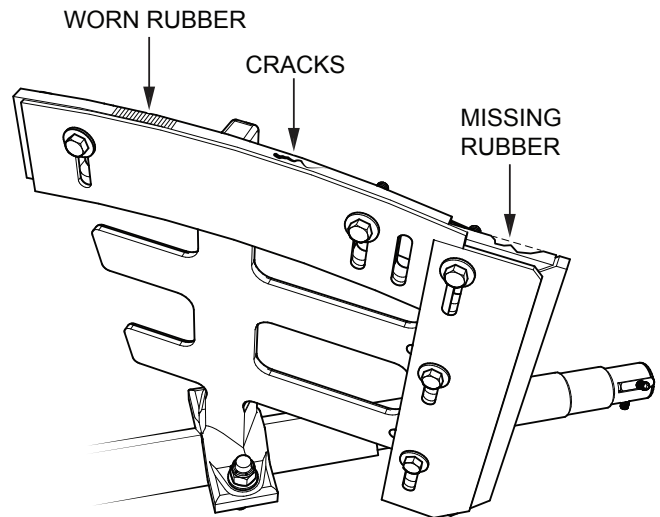

Figure 11. Worn Paddle Blade

CAUTION

NEVER disable or disconnect the **emergency stop switch**. It is provided for operator safety. Injury may result if it is disabled, disconnected or improperly maintained.

PADDLE BLADE ADJUSTMENT

STEEL DRUM

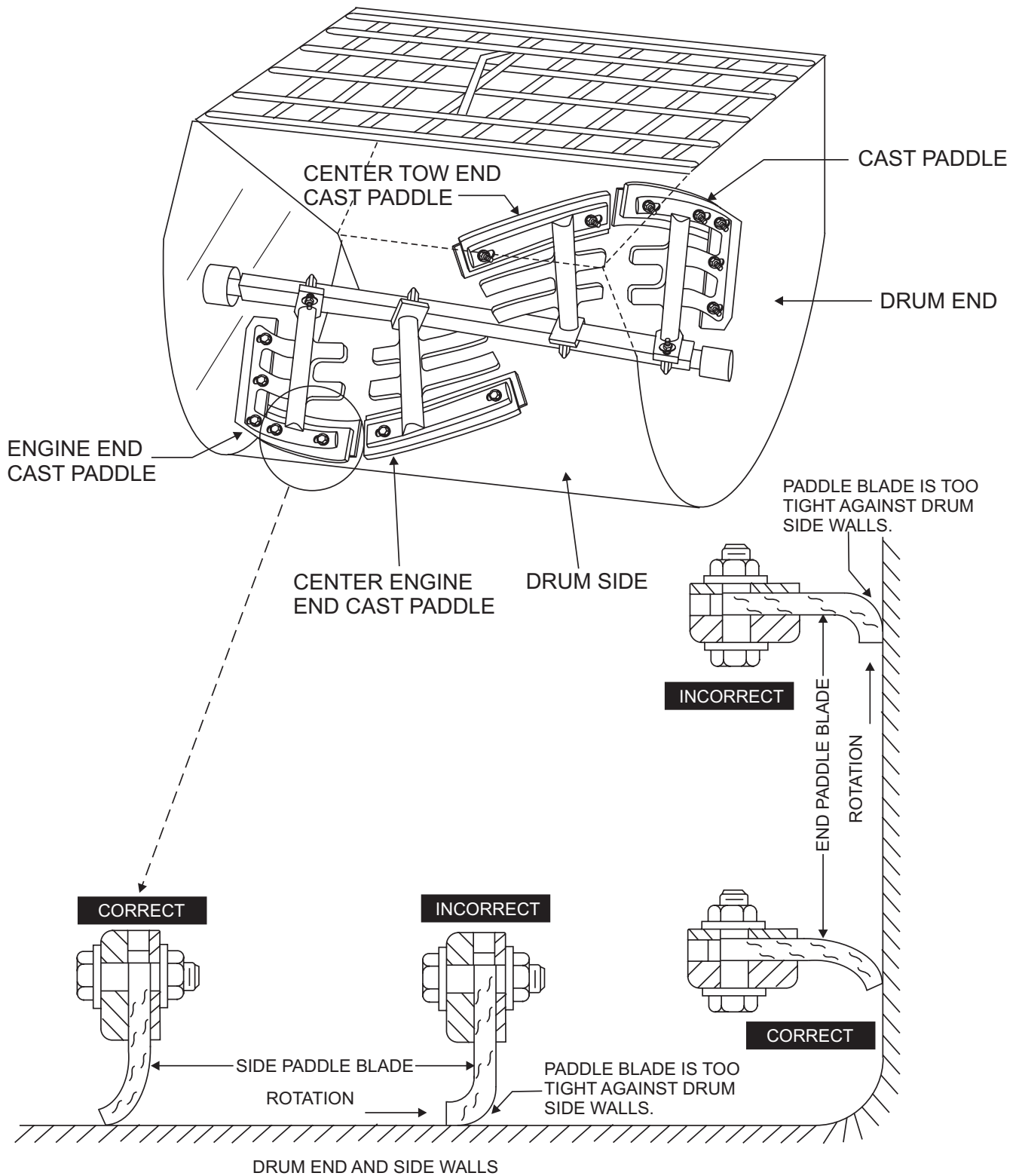

Figure 12. Paddle Blade Adjustment

CAUTION



DO NOT attempt to operate the mixer until the Safety, General Information and Inspection sections of this manual have been *read and thoroughly understood*.

This section is intended to assist the operator with the initial start-up of the mixer. It is extremely important that this section be read carefully before attempting to use the mixer in the field.

STARTING THE MIXER (GASOLINE ENGINE)

1. Make sure the hydraulic paddle control lever (Figure 13) is in the **neutral** position.

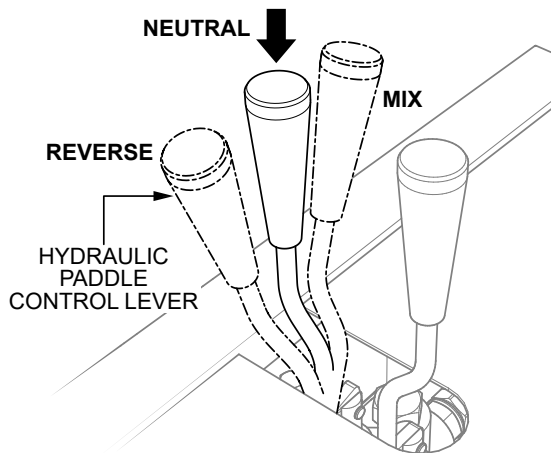

Figure 13. Hydraulic Paddle Control Lever (Neutral Position)

2. Place the engine fuel valve lever (Figure 14) in the **“ON”** position.

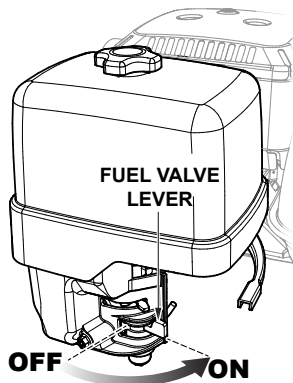

Figure 14. Engine Fuel Valve Lever (ON Position)

3. Move the throttle lever (Figure 15) away from the slow position, about 1/3 of the way toward the fast position.

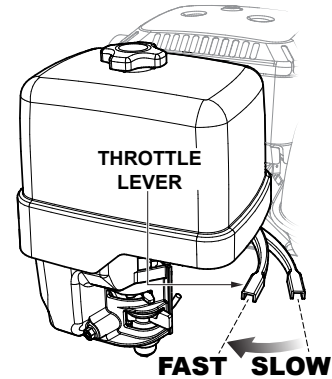

Figure 15. Throttle Lever (1/3 Start Position)

4. Place the choke lever (Figure 16) in the **“CLOSED”** position if starting a cold engine.

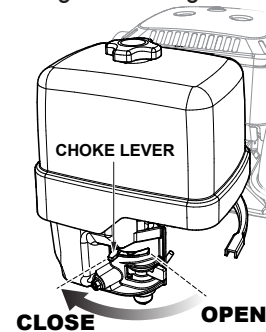

Figure 16. Engine Choke Lever (Closed)

5. Place the choke lever (Figure 17) in the **“OPEN”** position if starting a warm engine or the temperature is warm.

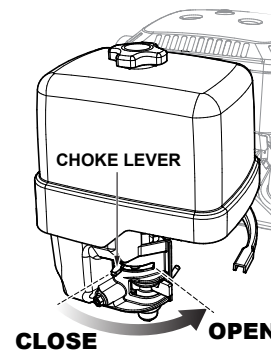

Figure 17. Engine Choke Lever (Open)

- Place the engine ON/OFF switch (Figure 18) in the "ON" position.

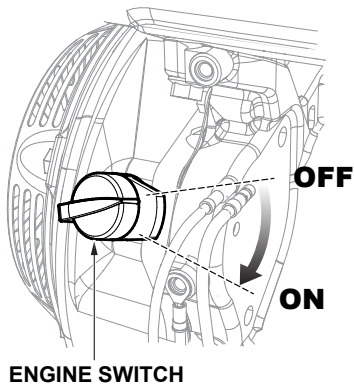

Figure 18. Engine ON/OFF Switch (ON Position)

- Locate the emergency stop switch (Figure 19) on the engine cover. Pull this button outward to allow engine starting.

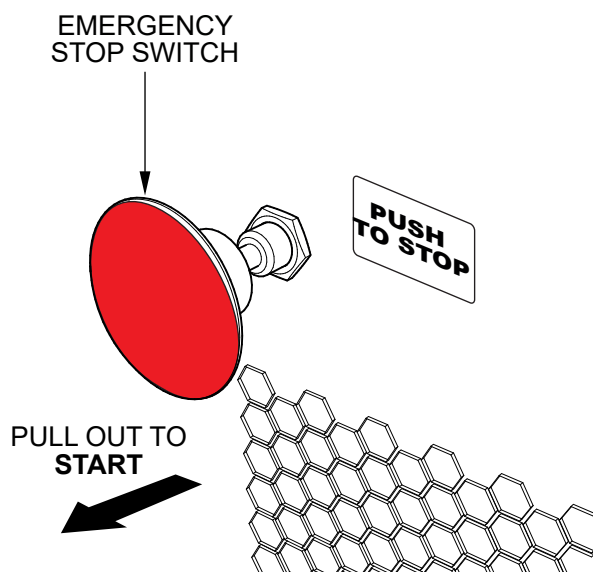

Figure 19. Emergency Stop Switch (Start Position)

- Turn the engine ignition key (Figure 20) to the **START** position and hold it until the engine starts. When engine starts, release the key, allowing it to return to the **ON** position.

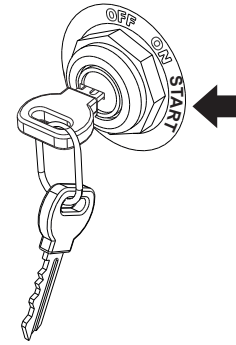

Figure 20. Engine Ignition Key

- If the choke lever was moved to the "CLOSED" position to start the engine, gradually move it to the "OPEN" position (Figure 21) as the engine warms up. If the engine has not started, repeat steps 1 through 8.

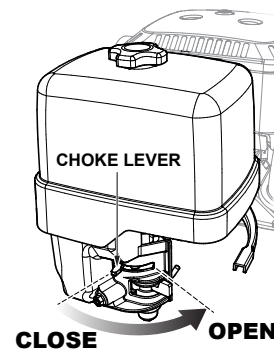

Figure 21. Choke Lever (Open)

- Before the mixer is placed into operation, run the engine for several minutes. Check for fuel leaks and noises that could be associated with a loose component.
- To begin mixing, place the throttle lever (Figure 22) in the "RUN" position.

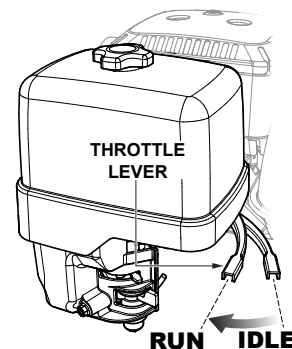

Figure 22. Throttle Lever (Run)

STARTING THE MIXER (ELECTRIC MOTOR)

- Using an appropriately sized extension cord (Table 7), connect one end of the extension cord to the plug on the electric motor, and connect the other end to the power source. Make sure the motor is configured for the proper operating voltage.

| Table 7. Cable Selection | | | | | | | |
|--------------------------|----------------------|-------|-------|-------|-------|-------|-------|
| Cord Length ft/m | Amperage/Load Rating | | | | | | |
| | 0-2 | 2-5 | 5-7 | 7-10 | 10-12 | 12-15 | 12-20 |
| 10 (3.0) | | | | | | | 12 GA |
| 25 (7.6) | 16 GA | 16 GA | 16 GA | 16 GA | 14 GA | 14 GA | |
| 50 (15.2) | 16 GA | 16 GA | 16 GA | 14 GA | 14 GA | 12 GA | |
| 100 (30.5) | 16 GA | 16 GA | 14 GA | 12 GA | 12 GA | | |
| 150 (45.7) | 16 GA | 14 GA | 12 GA | 12 GA | | | |
| 200 (61.0) | 14 GA | 14 GA | 12 GA | 10 GA | | | |

CAUTION: Equipment damage can result from low voltage.

NOTICE

Extension cords must be rated “**Heavy Duty**” or “**Extra Heavy Duty**” and must be a continuous length.

- Make sure the hydraulic paddle control lever (Figure 23) is in the **neutral** position.

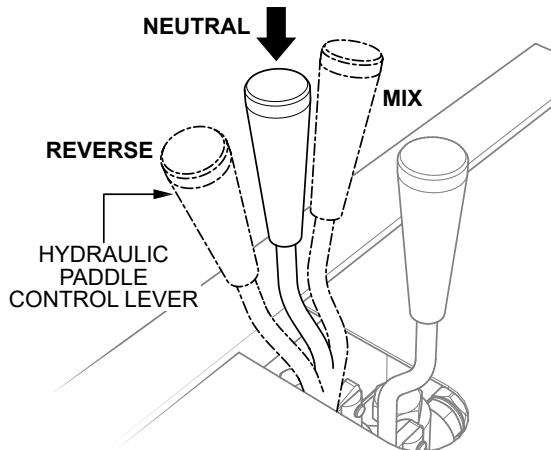

Figure 23. Hydraulic Paddle Control Lever (Neutral Position)

- To start the electric motor, press the black **ON/START** switch (Figure 24).

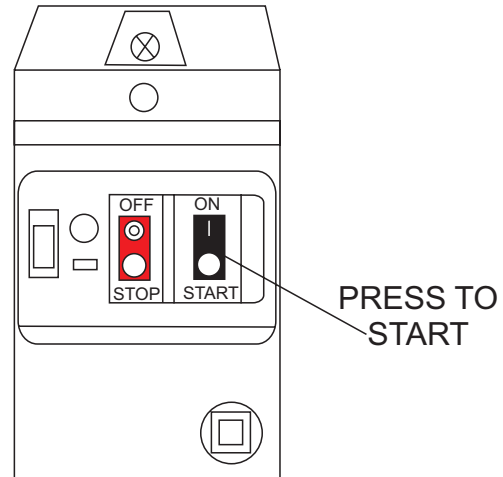

Figure 24. Electric Motor ON/OFF Switch (Start)

MIXING

- Push the hydraulic paddle control lever (Figure 25) forward for clockwise mixing rotation of the paddle blades.

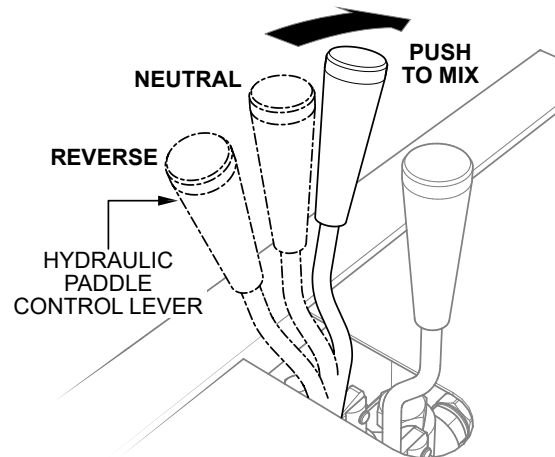

Figure 25. Hydraulic Paddle Control Lever (Mix Position)

- The paddle shaft inside the drum should be rotating at this time.
- Add a small amount of water to the mixing drum.
- Lift the mixing bag compound onto the steel safety grate over the bag cutter and let the contents fall into the drum. Add more water if desired and mix the compound to the desired consistency.

DUMPING

1. Push the hydraulic dump lever (Figure 26) forward to place the drum in the dump position (Figure 27).

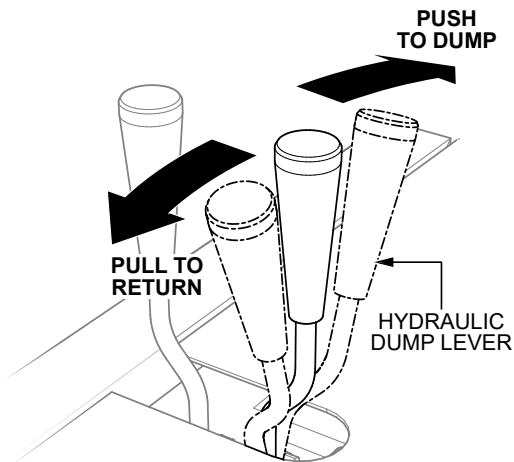

Figure 26. Hydraulic Dump Lever

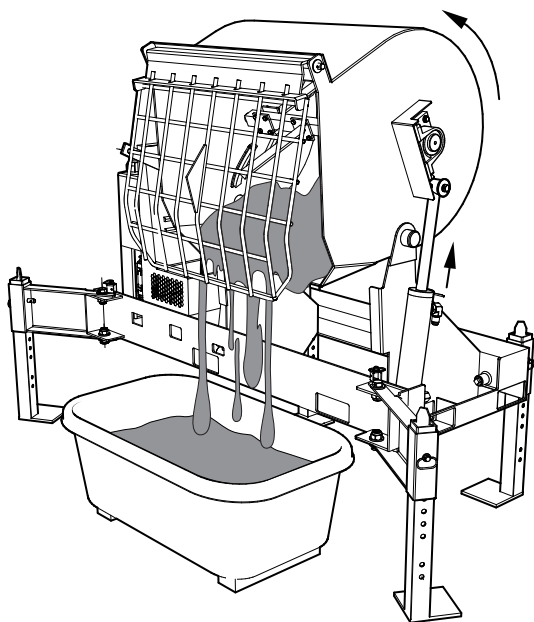
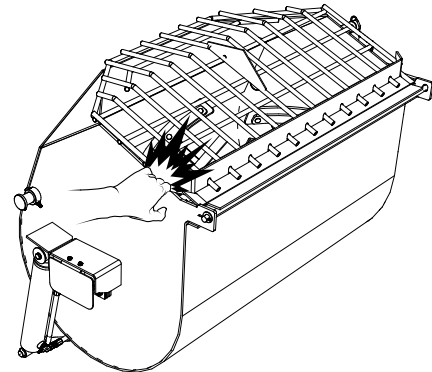

Figure 27. Hydraulic Dump

2. Pull the hydraulic dump lever backward to return the drum to the upright position.

WARNING

When rotating the mixing drum from the dump position to the upright position, keep hands clear of the safety grate. The possibility exists of hands or fingers being crushed.



STOPPING THE MIXER (GASOLINE ENGINE)

Normal Shutdown

1. Place the throttle lever in the **IDLE** (slow) position, and let the engine idle for 3–5 minutes. See Figure 28.

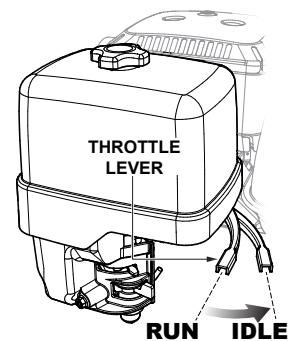

Figure 28. Throttle Lever (IDLE)

- Turn the engine ON/OFF switch (Figure 29) to the **OFF** position.

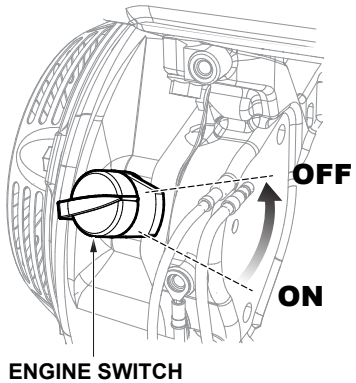

Figure 29. Engine ON/OFF Switch (OFF)

- Place the fuel valve lever (Figure 30) in the **OFF** position.

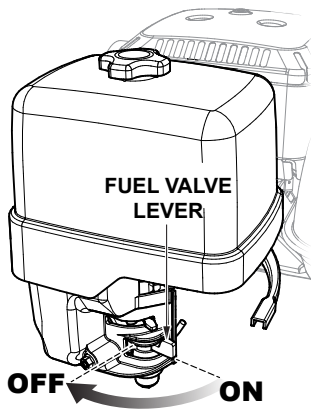

Figure 30. Fuel Valve Lever (OFF)

Emergency Shutdown

Push the emergency stop switch inward to the **STOP** position (Figure 31).

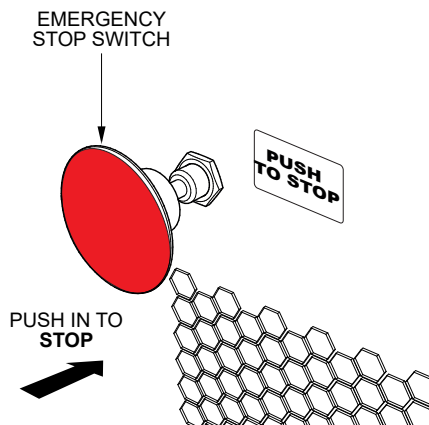

Figure 31. Emergency Stop Switch (STOP)

STOPPING THE MIXER (ELECTRIC MOTOR)

- To stop the electric motor, press the red OFF/STOP switch (Figure 32).

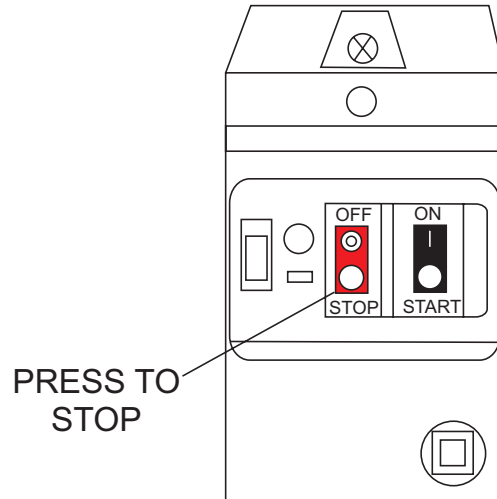

Figure 32. Electric Motor ON/OFF Switch (Stop)

- Disconnect the electric motor's extension cord from the power source.

CLEANING THE MIXER

After each use, thoroughly clean the entire mixer as described in the **Maintenance** section of this manual.

NOTICE

ALWAYS make sure the mixer drum is clean and free of debris and dried material. **DO NOT** allow material to build up inside the drum.

Keep the drum, frame and wheels clean. Excess debris (buildup of materials) can lead to premature metal fatigue.

MAINTENANCE

Perform engine maintenance procedures as scheduled in Table 8.

| Table 8. Engine Maintenance Schedule | | | | | | | |
|--------------------------------------|-------------------------|--|-----------------------|--------------------------|--------------------------|-----------------------|--------------------------|
| Description (3) | Operation | Before | First Month or 10 hrs | Every 3 Months or 25 hrs | Every 6 Months or 50 hrs | Every Year or 100 hrs | Every 2 Years or 200 hrs |
| Engine Oil | CHECK | X | | | | | |
| | CHANGE | | X | | | | |
| Air Cleaner | CHECK | X | | | | | |
| | CHANGE | | | X (1) | | | |
| All Nuts and Bolts | Re-tighten If Necessary | X | | | | | |
| Spark Plug | CHECK-CLEAN | | | | X | | |
| | REPLACE | | | | | | X |
| Cooling Fins | CHECK | | | | X | | |
| Spark Arrester | CLEAN | | | | | X | |
| Fuel Tank | CLEAN | | | | | X | |
| Fuel Filter | CHECK | | | | | X | |
| Idle Speed | CHECK-ADJUST | | | | | X (2) | |
| Valve Clearance | CHECK-ADJUST | | | | | | X (2) |
| Fuel lines | CHECK | Every 2 years (replace if necessary) (2) | | | | | |

1. Service more frequently when used in **DUSTY** areas.
2. These items should be serviced by your service dealer, unless you have the proper tools and are mechanically proficient. Refer to the **HONDA** Shop Manual for service procedures.
3. For commercial use, log hours of operation to determine proper maintenance intervals.

NOTICE

Refer to the engine manufacturer's manual for specific servicing instructions.

| Table 9. Mixer Maintenance Schedule | | | | |
|-------------------------------------|-----------|-------|--------|---------------|
| Description | Operation | DAILY | WEEKLY | Every 500 hrs |
| Bearings | GREASE | X | | |
| Shaft Seals | GREASE | X | | |
| Cylinder Pivot | GREASE | | X | |
| Hydraulic Oil | INSPECT | X | | |
| | REPLACE | | | X |

Perform engine maintenance as indicated below:

Daily

1. Thoroughly remove dirt and oil from the engine and control area.
2. Clean or replace the air cleaner elements as necessary.
3. Check and retighten all fasteners as necessary.

Weekly

1. Remove the fuel filter cap and clean the inside of the fuel tank.
2. Remove or clean the filter at the bottom of the tank.
3. Remove and clean the spark plug (Figure 33), then adjust the spark plug gap to 0.028–0.031 inch (0.7–0.8 mm). This unit has electronic ignition, which requires no adjustments.

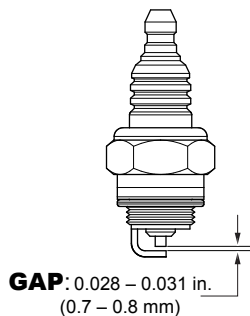

Figure 33. Spark Plug Gap

ENGINE OIL

NOTICE

ALWAYS drain the engine oil while the oil is **warm**.

1. Unscrew the oil filler dipstick (Figure 34) from its holder.

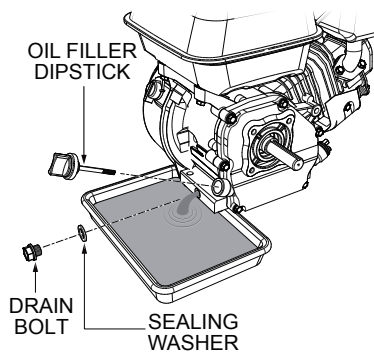

Figure 34. Draining Engine Oil

2. Remove the oil drain bolt and sealing washer and allow the oil to drain into a suitable container (Figure 34).
3. Reinstall the drain bolt with sealing washer and tighten securely.
4. Replace the engine oil with the recommended oil type listed in Table 6. **DO NOT** overfill. See Table 2 for engine oil capacity.

ENGINE AIR CLEANER

1. Remove the air cleaner cover and foam filter element as shown in Figure 35.

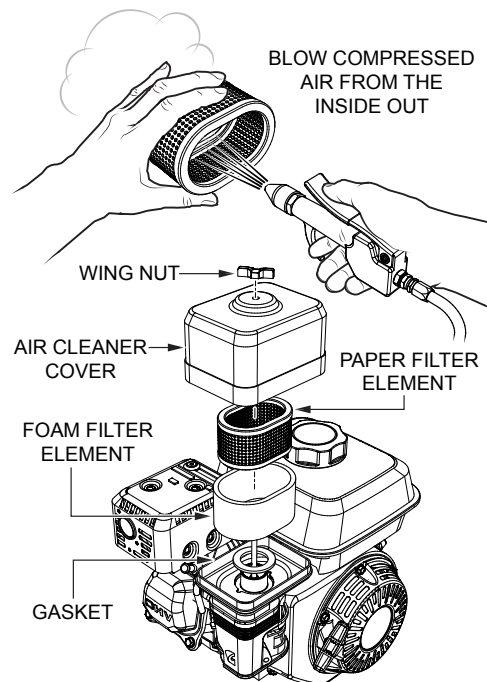

Figure 35. Engine Air Cleaner

2. To remove dirt, tap the paper filter element (Figure 35) several times on a hard surface, or blow compressed air not exceeding 30 psi (207 kPa, 2.1 kgf/cm²) through the filter element from the air cleaner case side. **NEVER** brush off dirt. Brushing will force dirt into the fibers. Replace the paper filter element if it is excessively dirty.
3. Clean the foam element in warm, soapy water or nonflammable solvent. Rinse and dry thoroughly. Dip the element in clean engine oil and completely squeeze out the excess oil from the element before installing.

DANGER



To avoid the risk of fire or an explosion, **NEVER** use gasoline as a cleaning solvent.

HYDRAULIC OIL FILTER

Replace the hydraulic oil filter (Figure 36) every 500 hours. Hydraulic tank capacity is 12 gallons (45 liters). Refill with Shell Tellus 46 hydraulic oil or equivalent.

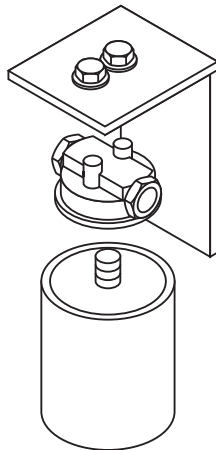

Figure 36. Hydraulic Oil Filter

MIXER CLEANING

NOTICE

It is important that the drum interior is kept free of dried material. Obstructions can cause the paddle blades to lock against the drum.

1. Stop the engine or electric motor. Follow the **Stopping the Mixer** procedure in the **Operation** section.
2. Place the hydraulic paddle control lever in the neutral position to disengage.
3. **ALWAYS** disconnect the spark plug wire before cleaning the inside of the drum.
4. Place a **Do Not Operate** tag on the mixer.
5. Make sure the rear section of the safety grate is connected to the mixing drum.

6. At the end of each day's operation, place the mixer drum in an upright position and spray the inside of the tub immediately with water. This will prevent lumps of dried mortar or plaster from forming and contaminating future batches. **DO NOT** allow a buildup of materials to form on the blades or anywhere inside the drum.
7. Rotate the mixer drum to the dump position and remove debris.
8. Thoroughly clean the entire mixer, cabinet and frame.

NOTICE

NEVER pour or spray water over the engine or electric motor (Figure 37).



Figure 37. No Spraying of Water

9. When cleaning of the entire mixer is complete, return the mixing drum to the upright position.

LONG-TERM STORAGE

For storage of the mixer for over 30 days, the following is recommended:

1. Drain the fuel tank completely, or add STA-BIL® to the fuel.
2. Run the engine until the fuel is completely consumed.
3. Completely drain used oil from the engine crankcase and fill with fresh, clean oil, then follow the procedures described in the engine manual for engine storage.
4. Clean the entire mixer and engine compartment.
5. Place the mixing drum in the inverted position (mouth facing downward).
6. Cover the mixer and place it in a clean, dry area that is protected from harsh elements.

TROUBLESHOOTING (ENGINE)

Practically all breakdowns can be prevented by proper handling and maintenance inspections, but in the event of a breakdown, please take remedial action following the diagnosis based on the troubleshooting tables. If the problem cannot be remedied, please leave the unit as is and consult our company's service department.

| Troubleshooting (Engine) | | |
|--|---|--|
| Symptom | Possible Problem | Solution |
| Difficult to start, fuel is available, but no spark at spark plug. | Spark plug bridging? | Check gap, insulation or replace spark plug. |
| | Carbon deposit on spark plug? | Clean or replace spark plug. |
| | Short circuit due to deficient spark plug insulation? | Check spark plug insulation, replace if worn. |
| | Improper spark plug gap? | Set to proper gap. |
| | Spark plug is red? | Check transistor ignition unit. |
| | Spark plug is bluish white? | If insufficient compression, repair or replace engine. If injected air leaking, correct leak. If carburetor jets clogged, clean carburetor. |
| | No spark present at tip of spark plug? | Check if transistor ignition unit is broken, and replace defective unit. Check if voltage cord cracked or broken and replace. Check if spark plug if fouled and replace. |
| | No oil? | Add oil as required. |
| | Oil pressure alarm lamp blinks upon starting? (if applicable) | Check automatic shutdown circuit, "oil sensor". (if applicable) |
| Difficult to start, fuel is available, and spark is present at the spark plug. | ON/OFF switch is shorted? | Check switch wiring, replace switch. |
| | Ignition coil defective? | Replace ignition coil. |
| | Improper spark gap, points dirty? | Set correct spark gap and clean points. |
| | Condenser insulation worn or short circuiting? | Replace condenser. |
| | Spark plug wire broken or short circuiting? | Replace defective spark plug wiring. |
| Difficult to start, fuel is available, spark is present and compression is normal. | Wrong fuel type? | Flush fuel system, replace with correct type of fuel. |
| | Water or dust in fuel system? | Flush fuel system. |
| | Air cleaner dirty? | Clean or replace air cleaner. |
| | Choke open? | Close choke. |
| Difficult to start, fuel is available, spark is present and compression is low. | Suction/exhaust valve stuck or protruded? | Reseat valves. |
| | Piston ring and/or cylinder worn? | Replace piston rings and/or piston. |
| | Cylinder head and/or spark plug not tightened properly? | Torque cylinder head bolts and spark plug. |
| | Head gasket and/or spark plug gasket damaged? | Replace head and spark plug gaskets. |
| No fuel present at carburetor. | No fuel in fuel tank? | Fill with correct type of fuel. |
| | Fuel cock does not open properly? | Apply lubricant to loosen fuel cock lever, replace if necessary. |
| | Fuel filter/lines clogged? | Replace fuel filter. |
| | Fuel tank cap breather hole clogged? | Clean or replace fuel tank cap. |
| | Air in fuel line? | Bleed fuel line. |

TROUBLESHOOTING (ENGINE)

| Troubleshooting (Engine) - continued | | |
|--|---|---|
| Symptom | Possible Problem | Solution |
| Weak in power, compression is proper and does not misfire. | Air cleaner dirty? | Clean or replace air cleaner. |
| | Improper level in carburetor? | Check float adjustment, rebuild carburetor. |
| | Defective spark plug? | Clean or replace spark plug. |
| | Improper spark plug? | Set to proper gap. |
| Weak in power, compression is proper but misfires. | Water in fuel system? | Flush fuel system and replace with correct type of fuel. |
| | Dirty spark plug? | Clean or replace spark plug. |
| | Ignition coil defective? | Replace ignition coil. |
| Engine overheats | Wrong type of fuel? | Replace with correct type of fuel. |
| | Cooling fins dirty? | Clean cooling fins. |
| | Intake air restricted? | Clear intake of dirt and debris. Replace air cleaner elements as necessary. |
| | Oil level too low or too high? | Adjust oil to proper level. |
| Rotational speed fluctuates. | Governor adjusted incorrectly? | Adjust governor. |
| | Governor spring defective? | Replace governor spring. |
| | Fuel flow restricted? | Check entire fuel system for leaks or clogs. |
| Recoil starter malfunctions. (if applicable) | Recoil mechanism clogged with dust and dirt? | Clean recoil assembly with soap and water. |
| | Spiral spring loose? | Replace spiral spring. |
| Starter malfunctions. | Loose, damaged wiring? | Ensure tight, clean connections on battery and starter. |
| | Battery insufficiently charged? | Recharge or replace battery. |
| | Starter damaged or internally shorted? | Replace starter. |
| Burns too much fuel. | Over-accumulation of exhaust products? | Check and clean valves. Check muffler and replace if necessary. |
| | Wrong spark plug? | Replace spark plug with manufacturer's suggested type. |
| Exhaust color is continuously "white". | Lubricating oil is wrong viscosity? | Replace lubricating oil with correct viscosity. |
| | Worn rings? | Replace rings. |
| Exhaust color is continuously "black". | Air cleaner clogged? | Clean or replace air cleaner. |
| | Choke valve set to incorrect position? | Adjust choke valve to correct position. |
| | Carburetor defective, seal on carburetor broken? | Replace carburetor or seal. |
| | Poor carburetor adjustment, engine runs too rich? | Adjust carburetor. |
| Will not start, no power with key "ON". (if applicable) | ON/OFF device not activated ON? | Turn on ON/OFF device. |
| | Battery disconnected or discharged? | Check cable connections. Charge or replace battery |
| | Ignition switch/wiring defective? | Replace ignition switch. Check wiring. |

TROUBLESHOOTING (MOTOR)

| Troubleshooting (Electric Motor) | | |
|------------------------------------|---|---|
| Symptom | Possible Cause | Solution |
| Electric motor will not start. | Is there power? | Check power source. Check reset button. |
| | Is power cable plugged in? | Plug in power cable. |
| | Is ON/OFF switch placed in ON position? | Place ON/OFF switch in ON position. |
| | Defective cable? | Check cable. |
| Electric motor continuously stops. | Reset button OK? | Check power source. |
| Electric motor RPM's too low. | Low voltage? | Check input voltage. |
| Electric motor RPM's too high. | High voltage? | Check input voltage. |

TROUBLESHOOTING (MIXER)

| Troubleshooting (Mixer) | | |
|--|---|--|
| Symptom | Possible Problem | Solution |
| Paddle blades will not rotate. | Worn or defective main (bull) gear? ¹ | Check main gear. Replace if worn or broken. |
| | Worn or defective pinion gear? ¹ | Check pinion gear. Replace if worn. |
| | Worn or defective V-belt? ¹ | Replace V-belt. |
| | Adjustment lever misaligned? ¹ | Check position of adjustment lever. Adjust if necessary. |
| | Material load too heavy, exceeding mixer capability? | Reduce amount of material being mixed. |
| | Object stuck inside mixing drum, jamming paddle rotation? | Stop engine. Empty out drum contents. Remove obstruction. |
| | Improper engine speed? ¹ | Check and adjust engine speed. |
| | Engine not running or stalls? ¹ | Check engine. |
| | Electric motor not connected? ¹ | Check electric motor. Apply power. |
| | Incorrect relief valve pressure? ² | Inspect for proper relief pressure. |
| | Defective hydraulic motor or pump? ² | Contact MQ Technical Services. |
| | Slow hydraulic cylinder dumping? ² | Contact MQ Technical Services. |
| | Contaminated relief cartridge? ³ | Inspect relief pressure. PRO12 = 1,750 psi PRO20 = 2,300 psi |
| Paddle blades rotate too slow. | Mixing paddles slipping under load? | Adjust idler wheel tension. ¹ |
| | Worn or defective V-belt? ¹ | Replace V-belt. |
| Material is leaking from drum ends. | Worn or defective paddle shaft seals? | Replace seals. |
| Drum is difficult to discharge (tilt). | Defective or worn drum support brackets? | Apply grease to brackets or replace. |
| | Blades adjusted too tight? | Adjust blades until they almost touch side walls of drum. |
| | Drum pivot bracket contaminated with dirt? | Grease bracket. |
| Main (bull) or pinion gear is worn. ¹ | Gears out of adjustment? | Inspect for proper gear backlash. Inspect that gears are properly centered. |
| Gear teeth are not contacting properly. ¹ | Worn or damaged pillow block bearings? | Adjust or replace pillow block bearings. |

¹ If equipped

² Hydraulic models only

³ Models PRO12 and PRO20 only

HYDRAULIC HOSE CONNECTIONS

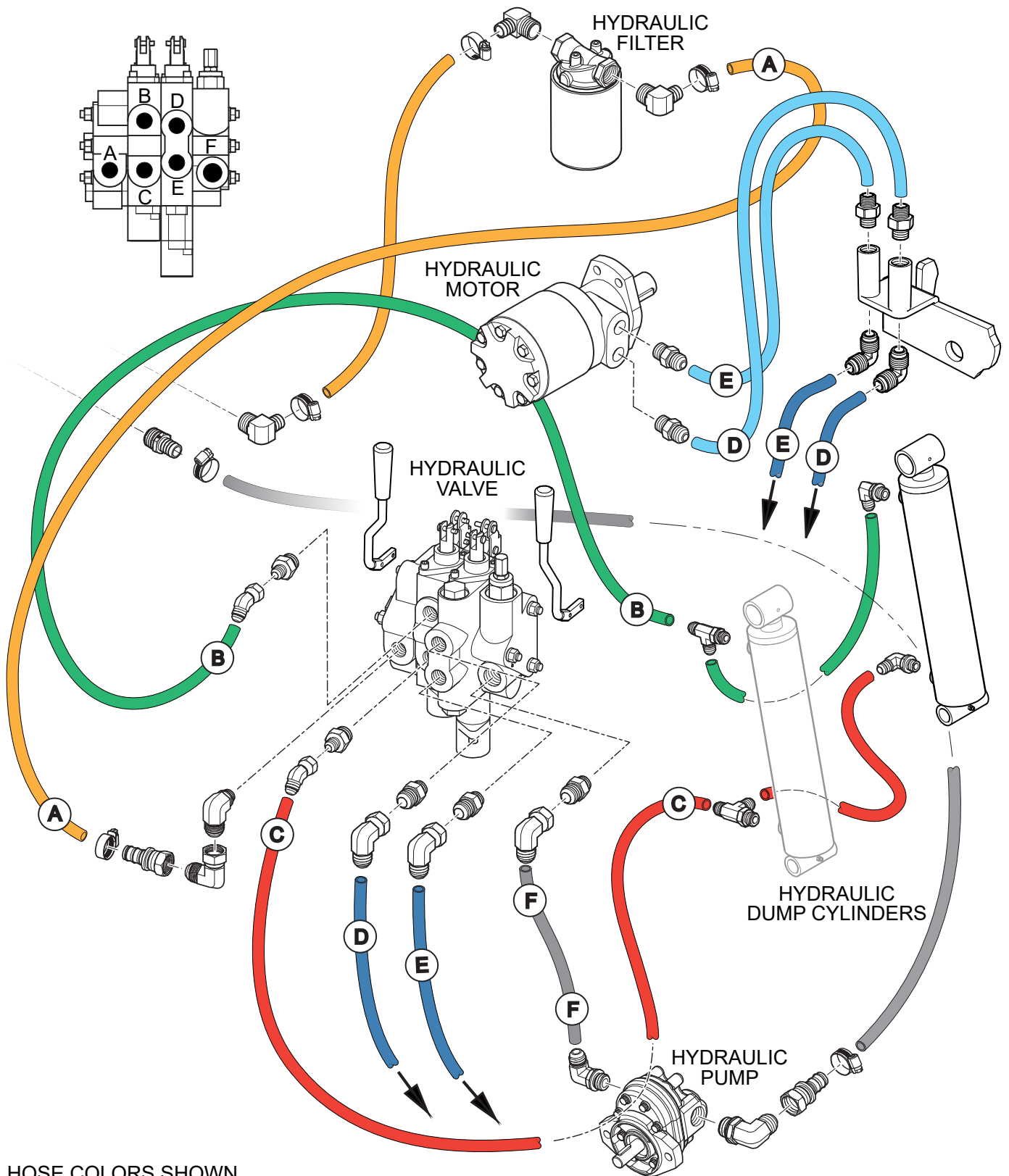

HOSE COLORS SHOWN
FOR CLARITY ONLY

HYDRAULIC SYSTEM LOCATOR

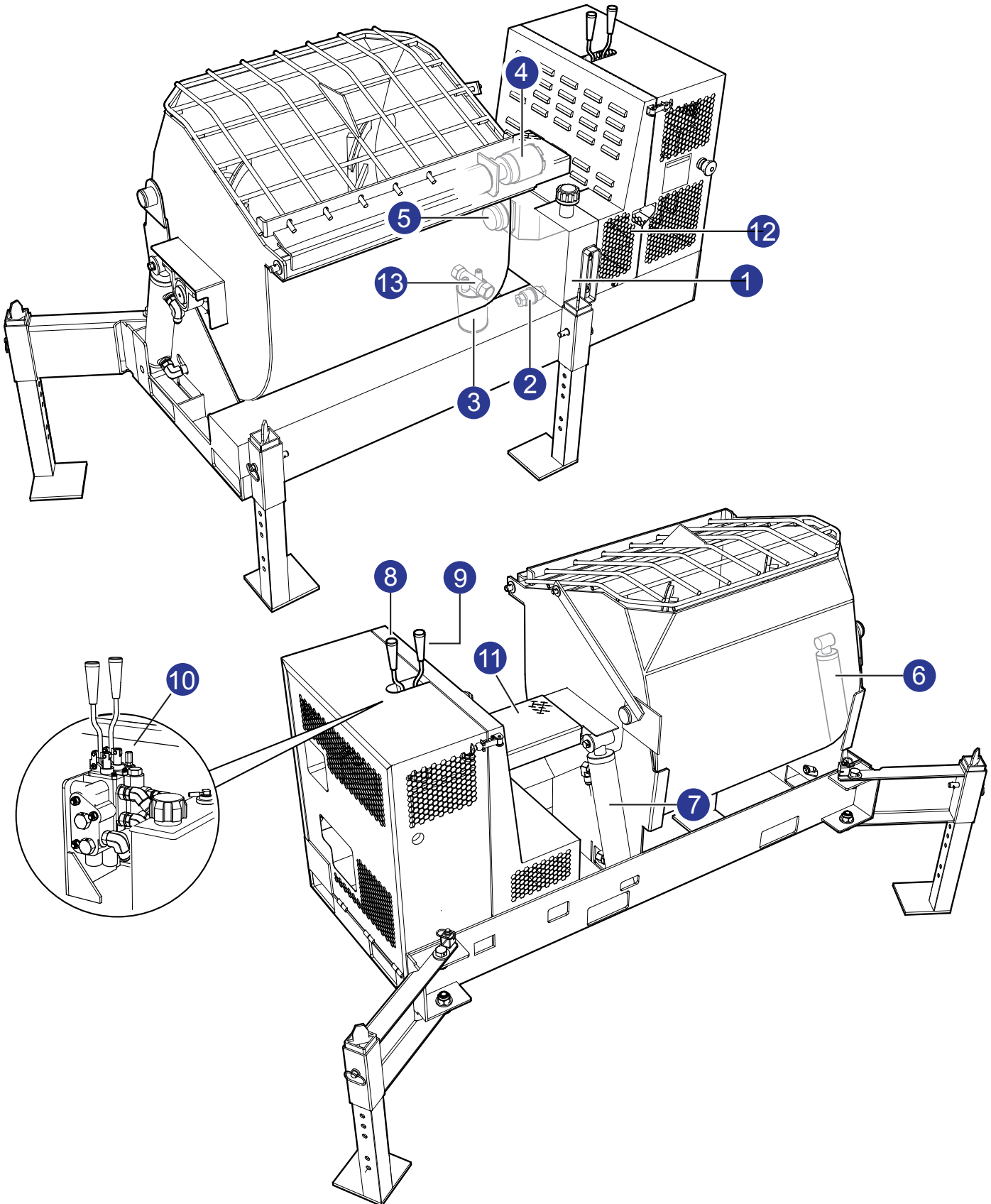

HYDRAULIC SYSTEM DIAGRAM

HYDRAULIC SYSTEM DIAGRAM

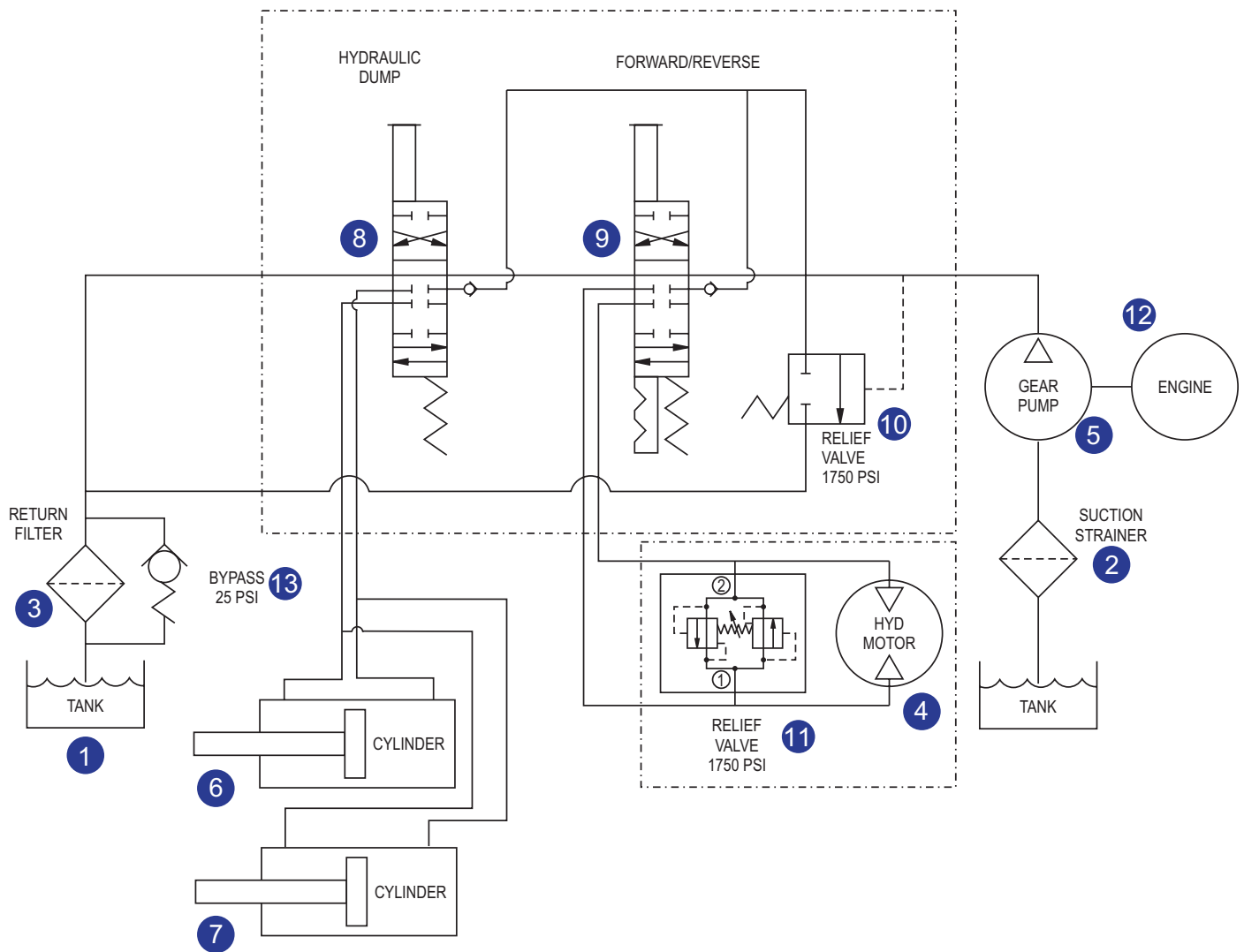

ELECTRIC MOTOR (SINGLE PHASE) WIRING DIAGRAM

2-POLE CIRCUIT BREAKER

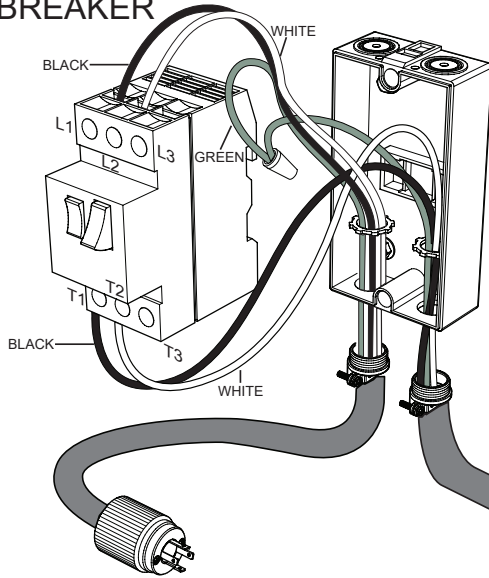

L6-30P
TWIST-LOCK

1Ø ELECTRIC MOTOR

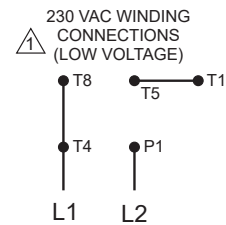
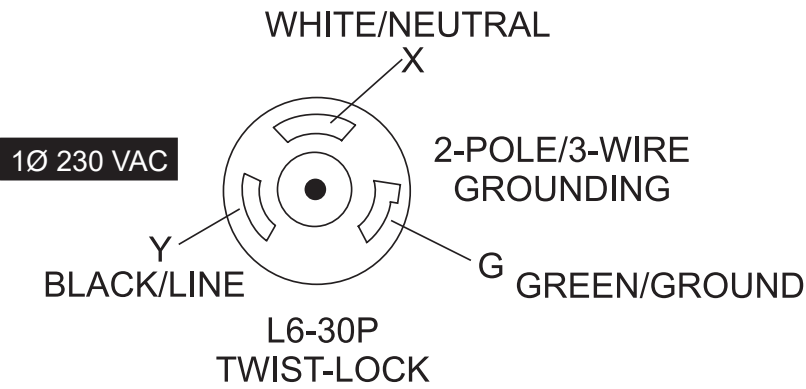
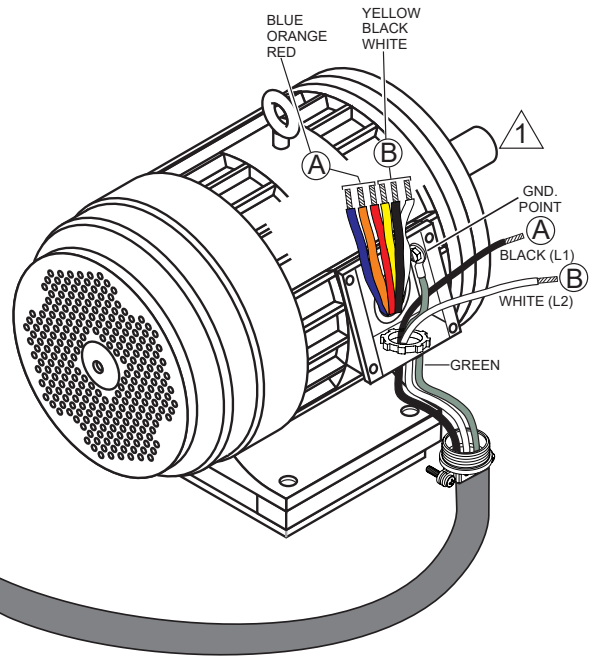

| COLOR CODE | |
|------------|--------|
| WIRE NO. | COLOR |
| 1 | BLUE |
| 2 | WHITE |
| 3 | ORANGE |
| 4 | YELLOW |
| 5 | BLACK |
| 6 | PURPLE |
| 7 | PINK |
| 8 | RED |
| 9 | GRAY |

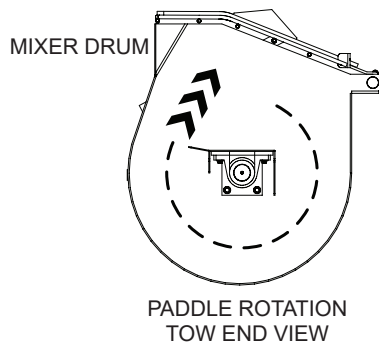

NOTE:
△ FACTORY WIRED 230 VAC.

ELECTRIC MOTOR (THREE PHASE) WIRING DIAGRAM

3-POLE CIRCUIT BREAKER

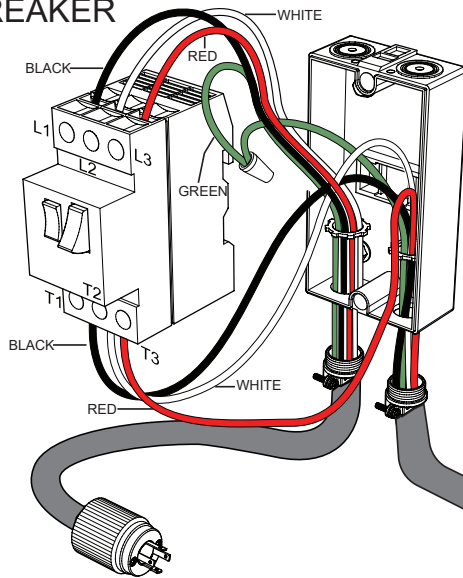

L15-30P OR L16-30P TWIST-LOCK

3Ø-PHASE ELECTRIC MOTOR

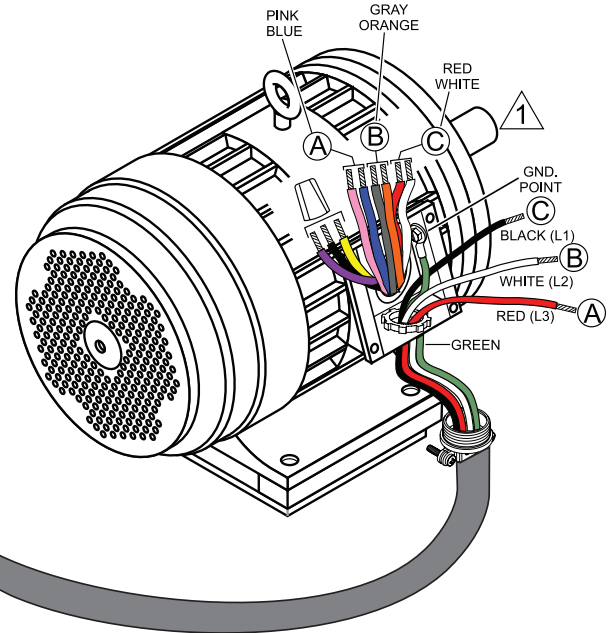

3Ø 230 VAC
L15-30P
TWIST-LOCK

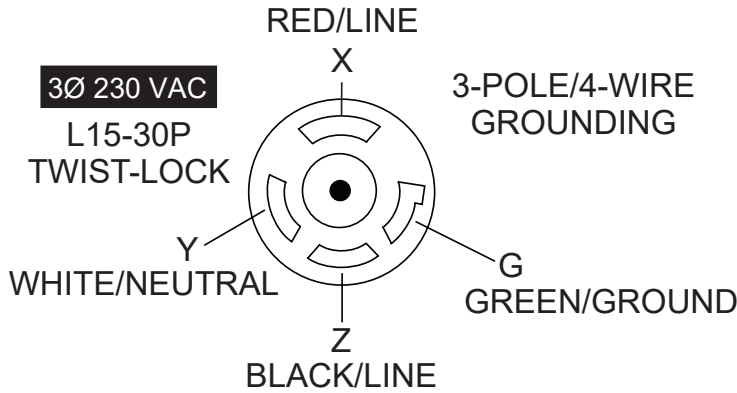

3Ø 460 VAC
L16-30P
TWIST-LOCK

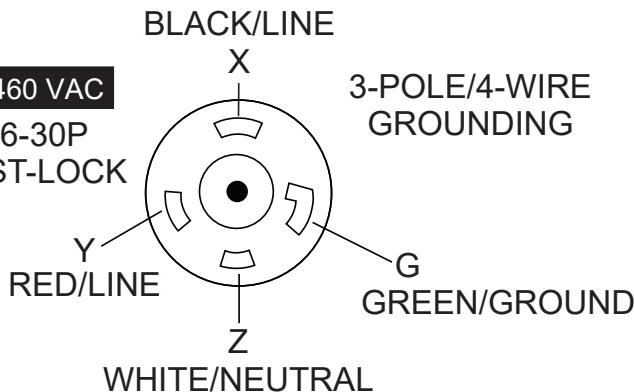

230 VAC WINDING CONNECTIONS (LOW VOLTAGE)

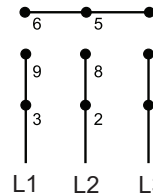

460 VAC WINDING CONNECTIONS (HIGH VOLTAGE)

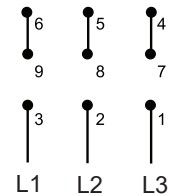

| COLOR CODE | |
|------------|--------|
| WIRE NO. | COLOR |
| 1 | BLUE |
| 2 | WHITE |
| 3 | ORANGE |
| 4 | YELLOW |
| 5 | BLACK |
| 6 | PURPLE |
| 7 | PINK |
| 8 | RED |
| 9 | GRAY |

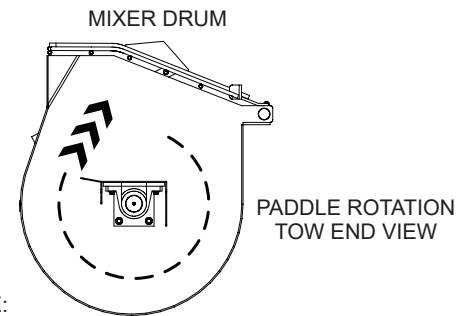

NOTE:
⚠ TO REVERSE DIRECTION OF SHAFT ROTATION, INTERCHANGE RED AND BLACK WIRE LEADS

OPERATION MANUAL

HERE'S HOW TO GET HELP

PLEASE HAVE THE MODEL AND SERIAL
NUMBER ON-HAND WHEN CALLING

UNITED STATES

Multiquip Inc.

(310) 537- 3700
6141 Katella Avenue Suite 200
Cypress, CA 90630
E-MAIL: mq@multiquip.com
WEBSITE: www.multiquip.com

CANADA

Multiquip

(450) 625-2244
4110 Industriel Boul.
Laval, Quebec, Canada H7L 6V3
E-MAIL: infocanada@multiquip.com

UNITED KINGDOM

Multiquip (UK) Limited Head Office

0161 339 2223
Unit 2, Northpoint Industrial Estate,
Globe Lane,
Dukinfield, Cheshire SK16 4UJ
E-MAIL: sales@multiquip.co.uk

© COPYRIGHT 2019, MULTIQUIP INC.

Multiquip Inc, the MQ logo are registered trademarks of Multiquip Inc. and may not be used, reproduced, or altered without written permission. All other trademarks are the property of their respective owners and used with permission.

This manual MUST accompany the equipment at all times. This manual is considered a permanent part of the equipment and should remain with the unit if resold.

The information and specifications included in this publication were in effect at the time of approval for printing. Illustrations, descriptions, references and technical data contained in this manual are for guidance only and may not be considered as binding. Multiquip Inc. reserves the right to discontinue or change specifications, design or the information published in this publication at any time without notice and without incurring any obligations.

