

TECHNICAL DATA

SINGLE DRUM ROLLERS

BW177 D-5

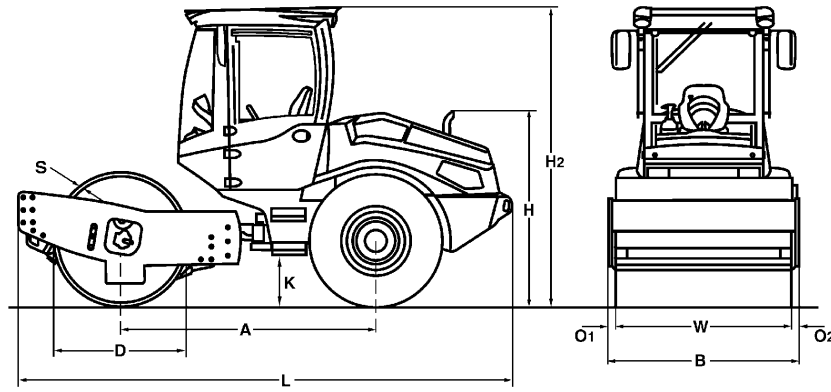



Dimensions in mm

	A	B	D	H	H2	K	L	O1	O1	S	W
BW177 D-5	2350	1820	1230	1654	2800	380	4550	65	65	20	1690

Shipping dimensions in m3

BW177 D-5

without ROPS

13,697

with ROPS

23,187

Machine type	Compaction output (m3/h)			
	Rock fill	Gravel, sand	Mixed soil	Silt, clay
BW177 D-5	-	210-420	160-320	70-140

Machine type	Compacted layer thickness (m)			
	Rock fill	Gravel, sand	Mixed soil	Silt, clay
BW177 D-5	-	0,45	0,35	0,15

Technical Data

BOMAG BW177 D-5

Weights

Grossweight	kg	7.800
Operating weight CECE w. ROPS-cabin	kg	6.600
Axle load, drum CECE	kg	4.000
Axle load, wheels CECE	kg	2.600
Static linear load CECE	kg/cm	23,7

Dimensions

Working width	mm	1.690
Track radius, inner	mm	2.975

Driving Characteristics

Speed (1)	km/h	0- 4,0
Speed (2)	km/h	0- 5,0
Speed (3)	km/h	0- 7,0
Speed (4)	km/h	0- 10,0
Max. gradeability without/with vibr.	%	49/46

Drive

Engine manufacturer		Deutz
Type		TD 2.9 L04
Emission stage		Stage V / TIER4f
Exhaust gas aftertreatment		DOC+DPF
Cooling		water
Number of cylinders		4
Performance ISO 3046	kW	55,4
Performance SAE J 1995	hp	75,0
Speed	min-1	2.400
Fuel		Diesel
Electric equipment	V	12
Drive system		hydrost.
Drum driven		standard

Drums and Tyres

Tyre size		14.9-24/8PR
-----------------	--	-------------

Brakes

Service brake		hydrost.
Parking brake		hydromec.

Steering

Steering system		oscil.artic.
Steering method		hydrost.
Steering / oscillating angle +/-	grad	35/12

Exciter system

Drive system		hydrost.
Frequency	Hz	29/32
Amplitude	mm	1,90/0,80
Centrifugal force	kN	112/74
Centrifugal force	t	11,4/7,5

Capacities

Fuel	l	110,0
------------	---	-------

Technical modifications reserved. Machines may be shown with options.

Standard Equipment

- BOMAG ECOMODE
- Self locking differential
- Rear axle with twin spring accumulator brakes
- Hydrostatic travel and vibration drive
- Hydrostatic articulated steering
- Articulated joint lock
- Warning, information and operation displays
- Single lever control for travel and vibration
- Emergency STOP
- Warning horn
- Back-up warning system
- Noise insulation
- 2 Contact scrapers Plastic

Optional Equipment

- * ROPS cabin with seat belts
- ROPS/FOPS with safety belt
- Tractor tires)
- * Working lights front/rear
- Indicator and hazard lights
- Rotary beacon
- Rearview camera
- Air condition
- Adjustable steering column
- Sliding window
- Radio (Bluetooth)
- BOMAG ECOSTOP
- ECONOMIZER
- TERRAMETER
- Printer for TERRAMETER
- BOMAG TELEMATIC
- BCM 05 Documentation system
- Special painting
- Reversing alarm buzzer with broad band audio
- Padfoot segment kit
- Environmentally compliant hydraulic oil
- Measuring- and machine data interface for third-party suppliers
- LED Working lights (Cabin)

* Standard delivery with CE conformity
(valid within European Union)

