



WHERE THERE IS PIPE, THERE'S MATHEY

4344 S. Maybelle Ave, Tulsa, OK 74107 USA
Toll Free: +1 800-725-7311 / +1 918-447-1288
Fax: +1 918-447-0188 / sales@mathey.com
www.mathey.com

2SA Saddle Machine

Parts & Operating Manual

Part Number: 03-0102-000 / 03-0102-S01

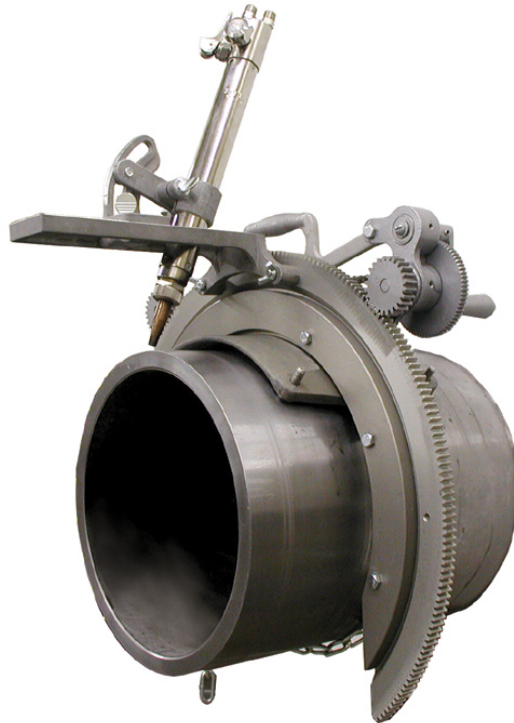

For future reference, record your Saddle Machine model and serial numbers here:

Saddle Machine Model _____ SA Serial # M _____ Manual ____ Motorized ____

REVISED: February 18, 2016
©Mathey Dearman, Inc.

Table of Contents

Item	Subject	Page#
1.0	Safety	3
2.0	General Information	7
3.0	Installation of Spacer Bolts	7
Picture 1	Spacer Bolt Box	7
Picture 2	Spacer Bolt Installation	7
Figure 1	Spacer Bolt Configurations	8
Table 1	Spacer Bolt Part Identification	8
Figure 2	Step Spacer Configuration	8
Table 2	Step Spacer Part Identification	8
Picture 3	Step Spacer Installation	9
4.0	Installation of Step Spacers	9
5.0	Installation of 2SA Saddle Machine on Pipe	9
Picture 4	Closing Boomer Latch	10
Figure 3	Boomer Assembly Parts Configuration	10
Table 3	Boomer Assembly Parts Identification	10
Figure 4	Torch Arm & Torch Carrier Configuration	11
Table 4	Torch Arm & Torch Carrier Parts Identification	11
6.0	Installation of Torch Arm, Torch Carrier Assembly and Torch	11
Picture 5	Installation of Torch Arm	11
Picture 6	Installation of Wing Nut	12
7.0	The Manual Cutting Process	12
8.0	The Motorized Cutting Process	13
Picture 7	Face of the Motor Control Box	13
Picture 8	End of the Motor Control Box	13
Picture 9	Cable, Motor Control Box to Stepper Motor	14
Figure 5	2SA Saddle Machine Parts Configuration	16
Table 5	2SA Saddle Machine Parts Identification	16
Figure 6	Single Bearing Bracket Configuration	17
Table 6	Single Bearing Bracket Parts Identification	17
Figure 7	Double Bearing Bracket Parts Configuration	17
Table 7	Double Bearing Bracket Parts Identification	17
Figure 8	Motorized 2SA Saddle Machine Parts Configuration	18
Table 8	Motorized 2SA Saddle Machine Parts Identification	19
Table 9	Trouble Shooting	20
9.0	Maintenance	21
9.1	Timing the Ring Gear to the Pinion Gear	21
9.2	Installation of a new Drive Chain	22
9.3	Retiming of the Machine with Stepper Motor	23
9.4	Replace of the Drive Chain of the Machine with Stepper Motor	23
9.5	Installation of the Stepper Motor Kit	24
9.6	Disassembly and Repair of the Single and Double Bearing Bracket	24
9.7	Storage	24
10.0	Limitations	24
11.0	Machine Safety	25
12.0	Condition of use	25
12.1	Condition of use	25
12.2	Use of the Saddle Machine not Allow by The Manufacturer	25
13.0	Disposal of the Saddle Machine	25
14.0	Warranty	26
Table 10	Commercial Pipe Sizes	26

1.0 SAFETY



ELECTRIC SHOCK CAN KILL

Electric Shock can injure or kill. Saddle machine operation and many cutting processes use or produce high voltage electrical energy. This electric energy can cause severe or fatal shock to the operator or others in the work place.

- Never touch any parts that are electrically “live” or “hot”
- Wear dry gloves and clothing. Insulate yourself from the work piece or other parts of the plasma cutting circuit.
- Repair or replace all worn or damaged parts.
- Extra care must be taken when work place is moist or damp.
- If installing a motorized saddle machine, install and maintain equipment according to NEC (National Electric Code), refer to publications section in this manual.
- Disconnect power source before performing any service or repairs.
- Read and follow all the instructions in the operating manuals.



FIRE AND EXPLOSION

Hot slag, sparks, oxygen-fueled cutting flame or the plasma arc can cause fire and explosion.

- Be sure there are no combustible or flammable materials in the workplace. Any material that cannot be removed must be protected.
- Ventilate all flammable or explosive vapors from the workplace.
- Do not cut or weld on containers that may have held combustibles.
- Provide a fire watch when working in an area where fire hazards may exist.



AUTOMATIC OPERATION

The Saddle Machine may operate automatically without warning. Keep the immediate area around the Saddle Machine clear of materials that may cause interference. Keep area clear of bystanders. All untrained persons should not work on or near a saddle machine. Do not leave the saddle machine unattended while power is on to any electronics.



NOISE

Noise can cause permanent hearing loss. Plasma arc cutting, oxy/fuel torch cutting, and grinding can cause noise levels that exceed safe limits. You must protect your ears from loud noise to prevent permanent loss of hearing.

- To protect your hearing from loud noise, wear protective earplugs and/or ear muffs. Protect others in the workplace.
- Noise levels should be measured to be sure the decibels (sound) do not exceed safe levels.
- For information on how to test for noise refer to the publications section of this manual



GASES, DUST, AND FUMES

Gases and fumes produced during the cutting process can be dangerous to your health.

- Keep all fumes and gases away from the breathing area. Keep your head out of the cutting fume plume.
- Use an air-supplied respirator if ventilation is not adequate to remove all fumes and gases.
- The kinds of fumes and gases from cutting depend on the kind of metal being cut, coatings on the metal, and the different processes. You must be very careful when cutting or welding any metals which may contain the following:

Antimony	Cadmium	Lead	Selenium	Arsenic	Chromium	Manganese	
Silver	Barium	Cobalt	Mercury	Vanadium	Beryllium	Copper	Nickel

Always read the Material Safety Data Sheet (MSDS) supplied with the material you are cutting. The MSDS will give you the information regarding the kind and amount of fumes and gases that may be produced from cutting and those that may be dangerous to your health

- For information on how to test for fumes and gases in your workplace refer to publications section of this manual.
- Use special equipment, if needed, to capture fumes and gases.
- Do not use in an area where combustible or explosive gases or materials are located.
- Phosgene, a toxic gas, is generated from the vapors of chlorinated solvents and cleansers. Remove all sources of these vapors.
- This product, when used for welding or cutting, produces fumes or gases which contain chemicals known to the State of California to cause birth defects and, in some cases, cancer. (California Health & Safety Code Sec. 25249.5 et seq.)
- Some dust created by cutting, grinding, drilling, and other construction activities contains chemicals known to cause cancer, birth defects or other reproductive harm. Some examples of these chemicals are:
 - Lead from lead-based paint.
 - Crystalline silica from bricks and cement and other masonry products.
 - Arsenic and chromium from chemically-treated lumber (CCA).
- Your risk from these exposures varies, depending on how often you do this type of work. To reduce your exposure to these chemicals: work in a well-ventilated area, and work with approved safety equipment, such as those dust masks that are specially designed to filter out microscopic particles.
- Avoid prolonged contact with dust from cutting, grinding, drilling, and other construction activities. Wear protective clothing and wash exposed areas with soap and water. Allowing dust to get into your mouth, eyes, or lay on the skin may promote absorption of harmful chemicals.



FLYING DEBRIS

Metal cutting operations can create debris. Use proper eye protection pursuant to ANSI Z87.1 requirements. All persons operating in the vicinity of Saddle Machine operations should be aware of debris and take necessary precautions. Consult the publications section of this manual for further information.



PLASMA ARC RAYS

Plasma Arc Rays can injure your eyes and burn your skin. The plasma arc process produces very bright ultraviolet and infrared light. These arc rays will damage your eyes and burn your skin if you are not properly protected.

- To protect your eyes, always wear a welding helmet or shield. Also, always wear safety glasses with side shields, goggles or other protective eye wear.
- Wear welding gloves and suitable clothing to protect your skin from the arc rays and sparks.
- Keep helmet and safety glasses in good condition. Replace lenses when cracked, chipped or dirty.
- Protect others in the work area from the arc rays. Use protective booths, screens or shields.
- Use the shade of lens as suggested in the following per ANSI/ASC Z49.1:



HEAVY COMPONENTS

Use caution when lifting or moving the saddle machine. Use team lifting when necessary to avoid personal injury. When using a mechanical device to move a machine follow all manufacturers' safety guidelines. Pipe being operated on with the machine may be heavy. Use all lifting guidelines outlined in Occupational Safety & Health Administration technical manual Sect. 7, Ch. 1.5. See publications section for additional information.



ELECTRIC AND MAGNETIC FIELDS

Electric current flowing through any conductor causes localized Electric and Magnetic Fields (EMF). Welding and plasma cutting current creates EMF fields around cables and machines. EMF fields may interfere with some pacemakers, and operators and observers having a pacemaker should consult their physician before operation. Exposure to EMF fields may also have other health effects which are now not known.



PINCH AND CRUSH POINTS

Mathey Dearman Saddle Machines in motion can create pinch points in normal operation. Be aware of all areas that may potentially be a hazard when the Saddle Machine is in motion. Avoid working on the machine while the control electronics are energized. Saddle Machines may use hard stop, while in motion these stops may be contacted creating a crush point. Do not allow hoses, cords or other nearby items to come in contact with the machine.



HOT MATERIALS

The process of plasma cutting creates an arc of electricity that can be up to 45,000°F (25,000°C). Oxygen-fuel cutting flame can be up to 6,330°F (3,500°C). As a result, cut materials will be very hot after cutting. Use extreme care when handling recently cut materials. Proper protective apparel such as protective gloves should be worn when handling recently cut material. Material handling devices should also be considered. It is recommended to allow material to cool completely before handling.



MECHANICAL DRIVES

Mechanical drives are in use while the Saddle Machine is in operation. These drives use gears and drive chains. These components can move at high speed. Do not attempt to service, adjust, or otherwise touch these components while the machine is on. Secure loose articles of clothing and cables to prevent entanglement.



AIR LINES UNDER PRESSURE

Certain tools and equipment use compressed air lines to operate. These air lines are under pressure. Hot sparks or flying debris may cause damage to these lines. Ensure that the air lines are kept free of punctures, burns, or other damage or defects that could cause failure. Inspect air lines periodically and repair or replace damaged lines.

PUBLICATIONS

Refer to the following standards or their latest revisions for more information:

- OSHA, SAFETY AND HEALTH STANDARDS, 29CFR 1910, obtainable from the Superintendent of Documents, U.S. Government Printing Office, Washington, D.C. 20402
- ANSI Standard Z49.1, SAFETY IN WELDING AND CUTTING, obtainable from the American Welding Society, 550 N.W. LeJeune Rd, Miami, FL 33126
- NIOSH, SAFETY AND HEALTH IN ARC WELDING AND GAS WELDING AND CUTTING, obtainable from the Superintendent of Documents, U.S. Government Printing Office, Washington, D.C. 20402
- ANSI Standard Z87.1, SAFE PRACTICES FOR OCCUPATION AND EDUCATIONAL EYE AND FACE PROTECTION, obtainable from American National Standards Institute, 1430 Broadway, New York, NY 10018
- ANSI Standard Z49.2, FIRE PREVENTION IN THE USE OF CUTTING AND WELDING PROCESSES, obtainable from American National Standards Institute, 1430 Broadway, New York, NY 10018
- AWS Standard A6.0, WELDING AND CUTTING CONTAINERS WHICH HAVE HELD COMBUSTIBLES, obtainable from American Welding Society, 550 N.W. LeJeune Rd, Miami, FL 33126
- NFPA Standard 51, OXYGEN-FUEL GAS SYSTEMS FOR WELDING, CUTTING AND ALLIED PROCESSES, obtainable from the National Fire Protection Association, Batterymarch Park, Quincy, MA 02269
- NFPA Standard 70, NATIONAL ELECTRICAL CODE, obtainable from the National Fire Protection Association, Batterymarch Park, Quincy, MA 02269
- NFPA Standard 51B, CUTTING AND WELDING PROCESSES, obtainable from the National Fire Protection Association, Batterymarch Park, Quincy, MA 02269
- CGA Pamphlet P-1, SAFE HANDLING OF COMPRESSED GASES IN CYLINDERS, obtainable from the Compressed Gas Association, 1235 Jefferson Davis Highway, Suite 501, Arlington, VA 22202
- CSA Standard W117.2, CODE FOR SAFETY IN WELDING AND CUTTING, obtainable from the Canadian Standards Association, Standards Sales, 178 Rexdale Boulevard, Rexdale, Ontario, Canada M9W 1R3
- NWSA booklet, WELDING SAFETY BIBLIOGRAPHY obtainable from the National Welding Supply Association, 1900 Arch Street, Philadelphia, PA 19103
- ANSI Standard Z88.2, PRACTICE FOR RESPIRATORY PROTECTION, obtainable from American National Standards Institute, 1430 Broadway, New York, NY 10018

2.0 GENERAL INFORMATION

- 2.1 2SA Saddle Machine is designed to rotate a 1 3/8"/35mm diameter 12" long oxy/fuel or plasma machine torch to cut and/or bevel 6"/152.4mm, 8"/203.2mm, 10"/254mm and 12"/304.8mm horizontal nominal size API line pipe. The machine comes with Spacer Bolts or Step Spacers for the above list pipe sizes. Spacer bolts are available for other pipe or tubing sizes within the machine cutting range.
- 2.2 **Operator Training** – The Operator requires no special training providing they read and understand the parts and operating manual. The training mainly involves teaching the operator to smoothly and without hesitation rotate the crank handle so the oxy/fuel or plasma torch produces a smooth even cut around the pipe.
- 2.3 **Maintenance Personnel** – Mathey Dearman offers a training course at its facility on the major machine repairs at no charge. The parts and operating manual contains information concerning the lubrication and minor repair.

3.0 INSTALLATION OF THE SPACER BOLTS

- 3.1 Select the correct Spacer Bolt for pipe being cut. The top of the spacer bolt storage box will help with the selection of the correct spacer for standard pipe sizes.

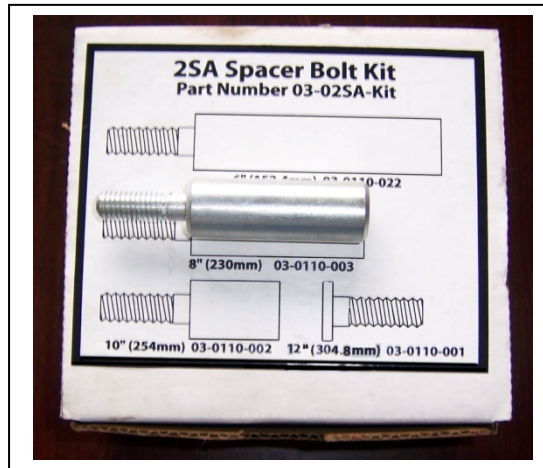

Picture 1 – Spacer Bolt Storage Box

- 3.2 Install the Spacer Bolts (4 bolts) in the four (4) holes in the 2SA Machine Saddle (Figure 5 item 1), with the Spacer End of the Bolts on the Bore (I.D.) side of the saddle.



Picture 2 – Spacer Bolt Installation

- 3.3 Secure Spacer Bolts to the Saddle by threading Hex Nut onto the threaded portion on the topside of Saddle. The hex nut does not have to be tightened with a wrench as the purpose of the nut is to secure the spacer bolt to the saddle.

Bore (inside diameter) of 2SA Saddle	Machine	13"	(330mm)
Subtract actual OD of pipe		8 5/8"	(219mm)
Difference		4-3/8"	(111mm)
Divide Difference by two (2)		$4-3/8" \div 2 = 2-3/16"$	(55.5mm)

The correct Spacer length (between outside diameter of pipe and inside diameter of saddle) is **2-3/16" (55.5mm)**.

Figure 1: Spacer Configuration for 6", 8", 10", & 12" pipe

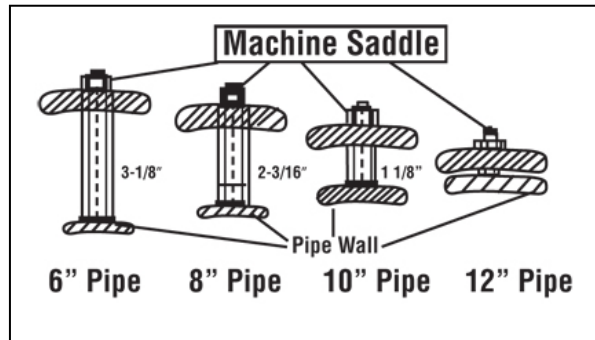

Table 1 – Spacer Bolt Part Identification

ITEM #	PART DESCRIPTION	PART #	QUANTITY REQUIRED
1	Spacer for 6" / 152mm pipe	03-0110-022	4
2	Spacer for 8" / 203mm pipe	03-0110-003	4
3	Spacer for 10" / 254mm pipe	03-0110-002	4
4	Spacer for 12" / 304mm pipe	03-0110-001	4
5	Spacer Bolt Kit (includes all of the above)	03-02SA-KIT	1

Figure 2: Step Spacer Configuration

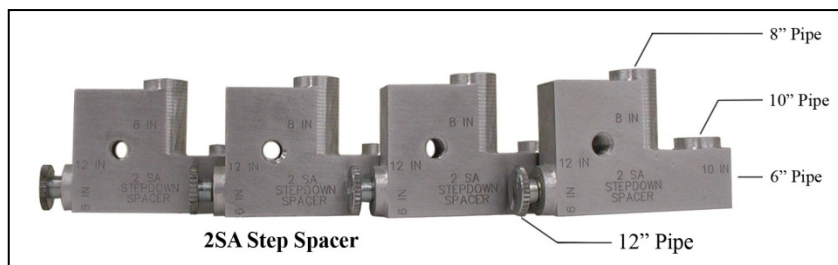
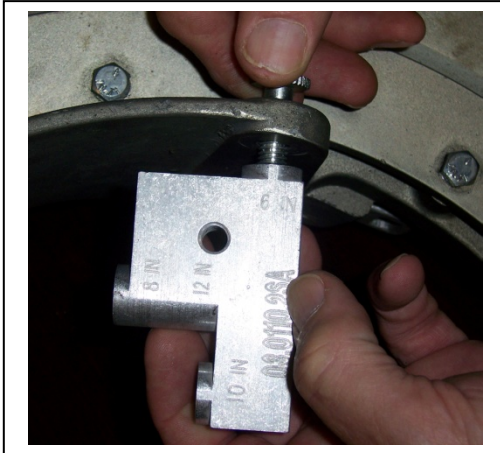

Table 2 – Step Spacer Part Identification

PART DESCRIPTION	Part #	QUANTITY REQUIRED
2SA Step Spacer	03-0110-2SA	4
12" Spacer Bolt (come with 2SA Step Spacer)	03-0110-2SAM	4
2Sa Step Spacer Kit	02-0110-2SA Kit	1

4.0 INSTALLATION OF THE STEP SPACERS

- 4.1 For 6", 8" and 10" pipe place the spacer bolt through the hole in the top of the saddle and tighten into the step spacer as shown in the pictures below.
- 4.2 For 12" pipe place the step spacer bolt on top side of the saddle with the flat side facing outward. Align the hole in the center of the step spacer with the hole on the top side of the saddle. Insert the spacer bolt through the hole in the bottom side of the saddle and tighten.
- 4.3 If it is necessary to securely tighten the step spacer a coin can be placed in the half moon slot on top of the spacer bolt.



6" Pipe

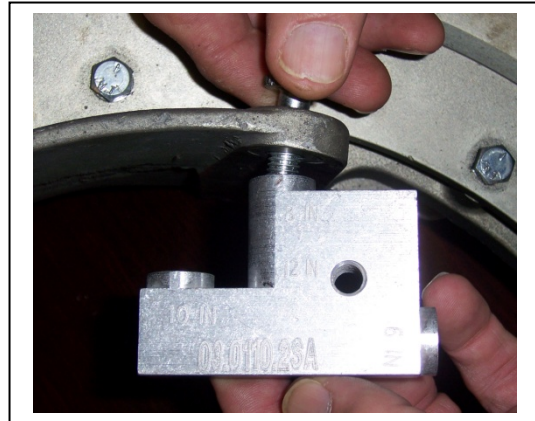

8" Pipe

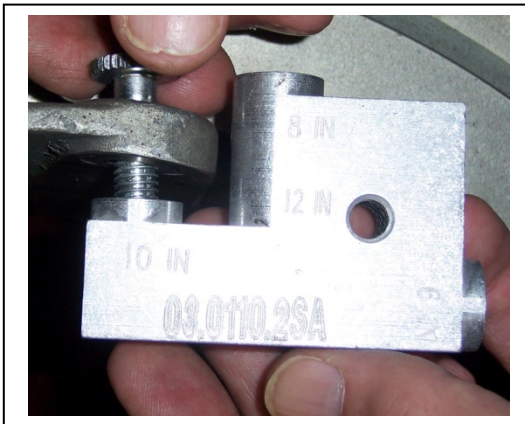

10" Pipe

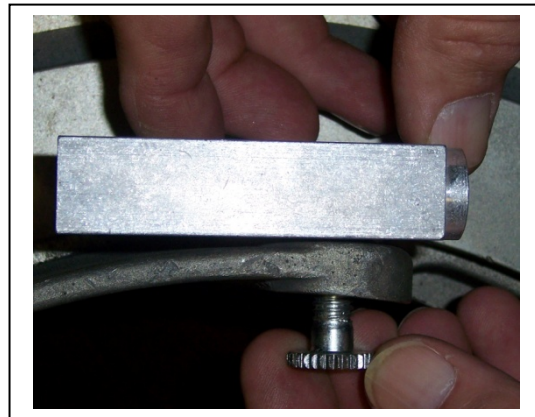

12" Pipe

Picture 3 – Step Spacer Installation

5.0 INSTALLATION OF THE 2SA SADDLE MACHINE ON THE PIPE

- 5.1 Place the 2SA Machine Saddle squarely on the pipe, as close as possible to the cut line. All 4 spacer bolts or step spacers should contact the pipe.
- 5.2 Place the hook of the Boomer (Figure 3 item 1) into the Boomer Eye (Figure 5 Item 7) on the Saddle (Figure 5 Item 1).
- 5.3 Place the Spring Snap (Figure 2 Item 4) into the Boomer Eye (Figure 5 Item 7) on the other side of the 2SA Saddle (Figure 5 Item 1).
- 5.4 In order to get a stable installation of the 2SA Saddle Machine, the Spring Snap (Figure 3 Item 4) of the Boomer Assembly (Figure 3) must be adjusted on the Chain (Figure 3 item 3) so that the spring is stretched approximately 1/2" - 3/4" (12 - 19mm) when the Boomer is closed.



WARNING: Improper tensioning of the boomer assembly or failure to latch the boomer assembly may result in injury.

5.5 When the Chain is properly adjusted, close the Boomer (Figure 3 item 1).

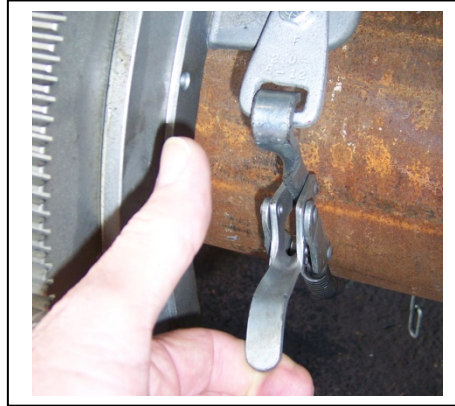

Picture 4 - Closing Boomer Latch



WARNING: Be careful not to get finger caught between the latch handle and boomer frame.

Figure 3: Boomer Assembly Part # 03.0102.011

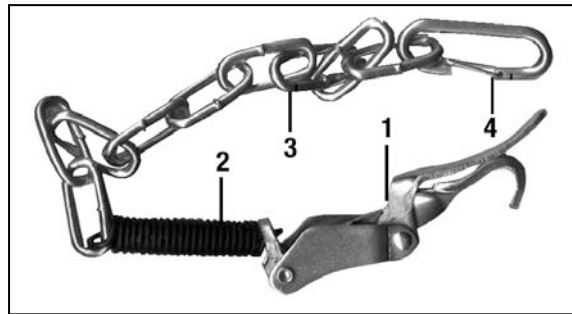

Table 3 - Boomer Assembly Parts Identification

ITEM #	PART DESCRIPTION	PART #	QUANTITY
1	Boomer	01-0258-001	1
2	Spring	01-0184-002	1
3	Chain	01-0577-003	1
4	Spring Snap	01-0258-003	1

**Figure 4: Torch Arm
Torch Carrier Assembly**

Part Number: 03-0101-001
Part Number: 03-0100-002

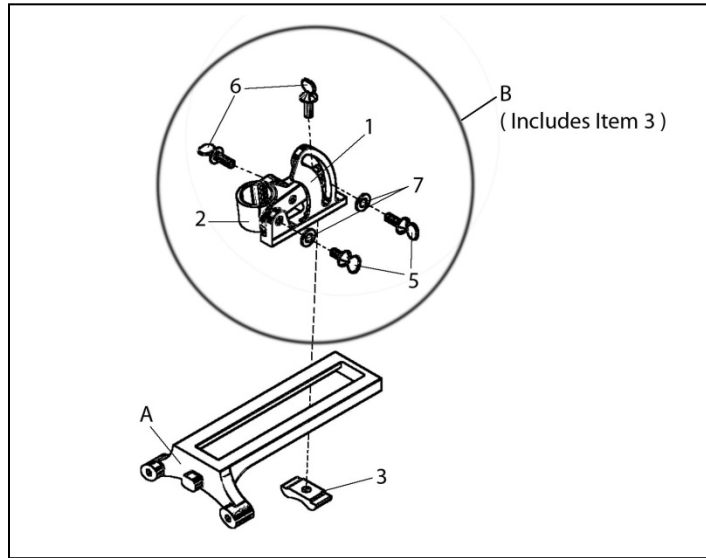

Table 4 - Torch Arm and Torch Carrier Parts Identification

ITEM #	PART DESCRIPTION	PART #	QUANTITY
A	Torch Arm	03-0101-001	1
B	Torch Carrier Assembly	03-0100-002	1
1	Torch Clamp Base	03-0100-003	1
2	Torch Clamp	03-0100-005	1
3	Clamp	03-0100-004	1
4	Screw Kit (includes 5, 6 & 7)	03-0100-029	1
5	Thumb Screw, 3/8-16 x 3/4"	22-38TS-034	2
6	Thumb Screw, 3/8-16 x 1"	22-38TS-100	2
7	Flat Washer, 3/8"	12-0038-F00	2

6.0 INSTALLATION OF THE TORCH ARM, TORCH CARRIER ASSEMBLY AND TORCH

6.1 Install Torch Arm (Figure 4, Item A) over the two threaded studs (Figure 5 item 14) in the face of the 2SA Machine Ring Gear (Figure 5 Item 3).



Picture 5 – Installation of Torch Arm on the Threaded Stud

6.2 Secure the Torch Arm to the Ring Gear with the wing nuts (Figure 5 item 15) provided in the Spacer Bolt Box.



Picture 6 – Installation of the Wing Nut

- 6.3 Remove the Clamp (Figure 4 Item 3) from the torch Carrier Assembly (Fig. 3, Item B).
- 6.4 Place the Torch Carrier Assembly (Figure 4 item B) on the Torch Arm (Figure 4 item A) with hole for Torch of the Torch Clamp (Figure 4 Item 2) nearest the ring gear.

NOTE: For the squarest cut place the torch as close to the Ring Gear (Figure 5 item 3) as possible

- 6.5 Reinsert Thumbscrew (Figure 4 Item 6) through the hole in the base of the clamp base (Figure 4 item 1) and thread it into the Clamp (Figure 4 item 3) securing the Torch Carrier Assembly to the Torch Arm.
- 6.6 The Torch Clamp Base (Fig. 4 Item 1) is marked 0, 60, and 90. Use “0” Position for square cuts (no bevel). positions 60 and 90 make the appropriate bevel to produce a “V” Groove of 60 and 90 degrees respectively when the two pipe ends are butted together.
- 6.7 Select the correct Cutting tip for the wall thickness and fuel gas per the torch manufactures instructions.
- 6.8 Insert 10” Long 1 3/8” diameter Machine Oxy/fuel or Plasma Machine Torch (not supplied) into Torch Clamp (Fig. 4, Item 2) and adjust torch tip to pipe height per the torch manufacturer instructions and tighten the Thumbscrew (Fig. 4, item 6) securing the Torch in the Torch Carrier Assembly.

NOTE: A 10” long Oxy/fuel or Plasma machine torch is required for the 2SA Saddle Machine to cut all pipes within its range.

7.0 THE MANUAL CUTTING PROCESS

- 7.1 Rotate Torch one full turn around the pipe to be sure torch tip will maintain the same distance around the pipe.

NOTE: If the torch tip contacts the pipe at any point during its rotation either the incorrect spacer bolts were selected or the pipe is oversize or out of round. If the distance of the torch tip is greater at the 6:00 position, either the incorrect spacer bolts were selected or the pipe is undersize or out of round.

If using the Plasma Machine Torch, skip to step 7.7 after completing 7.1

- 7.2 Connect the gas hose from the fuel regulator to the left hand thread port 10” long Oxy/fuel per the manufacturer’s instructions.
- 7.3 Connect the oxygen hose from the oxygen regulator to the right hand thread port 10” long Oxy/fuel per the manufacturer’s instructions.



WARNING: The oxygen and fuel hoses must be connected to the right port on the machine torch. Failure to do so may result in serious injury.



WARNING: The hose must not be drawn through the molten slag produced by the cutting process.



WARNING: Goggles, gloves, mask and other appropriate safety attire must be worn during the cutting process.

- 7.4 Adjust the oxygen and fuel gas regulator per the regulator manufacturer’s instructions.
- 7.5 Light the cutting torch per the torch manufacturer instructions.

NOTE: If the pipe is coated with Polyurethane, Carbo-Zinc, and Epoxy or is heavily rusted it will require that the coating be burnt off or removed by some other method in order to achieve a quality cut.

- 7.6 Follow the torch manufacturer's instructions for preheating the pipe.
- 7.7 While rotating the machine torch around the pipe, move the cutting oxygen valve to the ON position to penetrate the pipe per the torch manufacturer's instructions (if using the Plasma Machine torch, activate per the torch manufacturer instructions).
- NOTE:** If the torch penetrates the pipe without the machine being rotated it will create a notch in the bevel that is unacceptable to most welding codes.

 **WARNING:** Keep hands and clothing away from the gearing as it will cause serious injury.

- 7.8 Rotate the torch around the pipe until the cut is complete.
- 7.9 If using a Plasma torch, turn off per the torch manufacturer instructions. If using an Oxy/fuel torch, proceed to steps 7.10-7.12.
- 7.10 Rotate the cutting oxygen valve of the cutting torch to the OFF position per the torch manufacturer's instructions.
- 7.11 Close the fuel and oxygen valve of the torch per the torch manufacturer's instructions.
- 7.12 Close the valve on the Oxygen and fuel gas bottles if no further cuts are to be made per the torch manufacturers instructions.

 **WARNING:** The pipe and debris from the cutting process are extremely hot and cause serious injury or death.

8.0 THE MOTORIZED CUTTING PROCESS

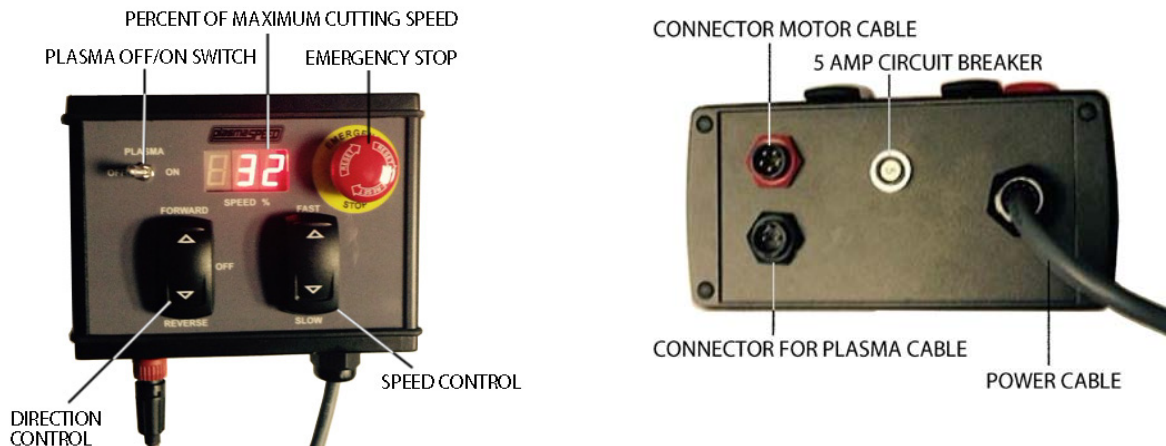

 **WARNING:** Motor Control Box is designed for use with single phase 90 -240 volts alternating current (AC). Use of a higher current will result in serious injury or death

 **WARNING:** Motor Control Box is **not** designed for use with direct current (DC). Connection of the Motor Control Box to direct current will result in serious injury or death.

- 8.1 Installation of Torch Arm, Torch Carrier Assembly and Oxy/fuel or Plasma Torch per instruction in 6.0
- 8.2 Depress the Emergency Stop Switch.
- 8.3 Connect the Motor Cable to surface mount connector of the Motor Control Box.
- 8.4 Connect the other end of the motor cable to the motor assembly.
- NOTE:** Verify the cable lock feature is engage at both ends of the motor cable.

NOTE: If using a plasma torch system, connect the plasma cable between the Motor Control Box and the plasma torch system in the same manner. Verify the cable lock feature is engaged at both ends.

Make sure the Plasma Switch is in the “Off” position.

- 8.5 Connect the Motor Control Box power cable to the AC electrical receptacle.
- 8.6 Twist to release the Emergency Stop Switch.
- 8.7 The digital screen will light with the following.
 - 991 – Indicates that a NEMA 23 motor is in use.
 - 992 – Indicates that a NEMA 34 motor is in use.
 - 993 – Indicates that a heavy-duty NEMA 34 motor is in use.
 - 994 & 995 – Check cable connection at Motor Control Box and Motor.
 - 999 – Indicates the Directional Control Switch is in the “Forward” or “Reverse” position. Move to the “Off” position.
- 8.8 If no faults are present after the motor number appears, the percent of maximum speed will be displayed in the window.
- 8.9 Move the Directional Control Switch to the “Forward” or “Reverse” direction.
- 8.10 Depress the Speed Control Switch until the percent of motor speed reads about 32% or machine speed or control of the machine can be maintained should an emergency arise.
- 8.11 Rotate Torch one full turn around the pipe to be sure torch tip will maintain the same distance around the pipe.

NOTE: If the torch tip contacts the pipe or is further away from the pipe at any point during its rotation either the incorrect spacer bolts were selected or the pipe is oversize, undersize or out of round.
- 8.12 Depress the Emergency Stop Switch.
- 8.13 Disconnect the Motor Control Box power cable from the AC electrical receptacle.

If using a Plasma Torch, skip to step 8.17.
- 8.14 Connect the gas hose from the fuel regulator to the left hand thread port 10” long Oxy/fuel per the manufacturer’s instructions.
- 8.15 Connect the oxygen hose from the oxygen regulator to the right hand thread port 10” long Oxy/fuel per the manufacturer’s instructions.



WARNING: The oxygen and fuel hoses must be connected to the right port on the machine torch. Failure to do so may result in serious injury.



WARNING: The Oxygen and fuel gas hoses must not be drawn through the molten slag produced by the cutting process



WARNING: Goggles, gloves, mask and other appropriate safety attire must be worn during the cutting process.

- 8.16 Adjust the oxygen and fuel gas regulator per the regulator manufacturer’s instructions.
- 8.17 Connect the Motor Control Box power cable to the AC electrical receptacle.
- 8.18 Twist to release the Emergency Stop Switch.
- 8.19 Verify the percent of maximum speed is displayed in the window.
- 8.20 Depress the Speed Control Switch until the percent of motor speed reads about 32% so control of the machine can be maintained should an emergency arise.
- 8.21 Move the Directional Control Switch to the “Forward” or “Reverse” direction. **If using a Plasma Torch, skip to step 8.24**
- 8.22 Light the cutting torch per the torch manufacturer instructions.

NOTE: If the pipe is coated with Polyurethane, Carbo Zinc, and Epoxy or is heavily rusted it will require that the coating be burnt off or removed by some other method in order to achieve a quality cut.
- 8.23 Follow the torch manufacturer’s instructions for preheating the pipe.
- 8.24 While the machine is rotating around the pipe, move the cutting oxygen valve to the ON position to penetrate the pipe per the torch manufacturer’s instructions.

NOTE: If using a plasma torch in conjunction with the Motor Control Box, depress the Plasma On / Off button on the Motor Control Boxes at this time to turn the plasma torch on. (The plasma cable is designed for use with a Hypertherm, Thermal Dynamics, Victor or new ESAB plasma system.)

NOTE: If the torch penetrates the pipe without the machine being rotated it will create a notch in the bevel that is unacceptable to most welding codes.



WARNING: Keep hands and clothing away from the gearing as it will cause serious injury.

- 8.25 Adjust the torch travel speed with Speed Control Switch until a quality cut is achieved.
- 8.26 Rotate the torch around the pipe until the cut is complete.
- 8.27 If using an Oxy/fuel torch, rotate the cutting oxygen valve of the cutting torch to the OFF position per the torch manufacturer's instructions. If using a Plasma torch, it will be necessary to depress the Plasma On / Off button on the Motor Control Box to turn the torch off.
- 8.28 Depress the Emergency Stop Switch.
- 8.29 If using a Plasma torch, skip to step 8.32
- 8.30 Close the fuel and oxygen valve of the torch per the torch manufacturer's instructions.
- 8.31 Close the Oxygen and fuel valve on the gas bottles per the torch manufacturer's instructions.
- 8.32 Disconnect the Motor Control Box power cable from the electrical receptacle.
- 8.33 Move the Directional Control Switch to the "Off" position.



WARNING: The pipe and debris from the cutting process are extremely hot and can cause serious injury.

A NOTE ON BACK BEVELING

Remove the torch from the torch carrier assembly. Rotate the Torch Clamp Base and Torch 180 degrees on the Torch Arm and re-tighten with thumbscrew and clamp. Reinstall the torch into the torch carrier assembly. When back beveling, place Torch as close to Saddle as possible without placing flame directly on or near Saddle. The Torch is now positioned for back beveling.



WARNING: When back beveling, the cutting flame and "hot" zone of the pipe is directed toward the operator.

Figure 5 – 2SA Saddle Machine Configuration Part #03-0102-000

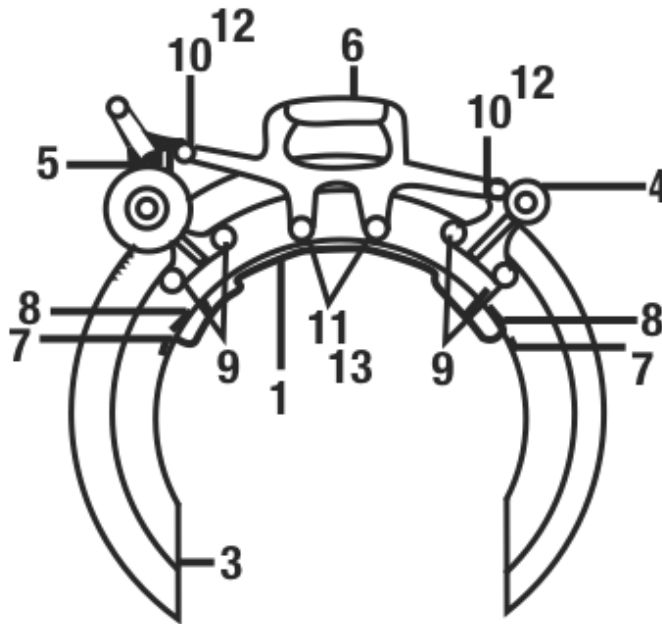
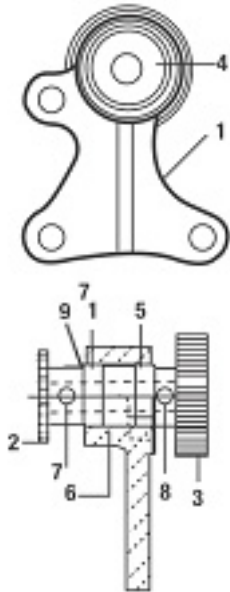

Table 5 - 2SA Saddle Machine Parts Identification

ITEM #	DESCRIPTION	PART #	QTY.
1	Saddle	03-0102-001	1
2	Cap Ring	03-0102-003	1
3	Ring Gear	03-0102-002	1
4	Single Bearing Bracket Assembly	03.0102-004	1
5	Double Bearing Bracket Assembly	03-0102-007	1
6	Tie Rod Handle	03-0102-010	1
7	Boomer Eye	03-0101-017	2
8	Cap Screw, Hex Head, 5/16", 18NC x 1/2"	10-56C0-012	2
9	Cap Screw, Hex Head, 5/16", 18NC x 3/4"	10-56C0-034	4
10	Cap Screw, Hex Head, 5/16", 18NC x 7/8"	10-56C0-078	2
11	Cap Screw, Hex Head, 5/16", 18NC x 1"	10-56C0-100	2
12	Nut, Hex 5/16" - 18NC	1H-56C0-000	2
13	Nut, Hex 3/8", 16NC	1H-38C0-000	2
14	Threaded Stud (not shown in Ring Gear)	01-0194-003	2
15	Wing Nut, 5/16"-18NC (not shown)	1W-56C0-000	2
16	Drive Chain (not shown)	03-0102-009	1
17	Cap Screw, Hex Head, 5/16", 18NC x 5/8"	10-56C0-058	6

Figure 6 - Single Bearing Bracket Assembly Part # 03-0102-004

Table 6 - Single Bearing Bracket Assembly Part Identification



ITEM #	DESCRIPTION	PART #	QTY.
1	Bracket	03-0102-005	1
2	Sprocket	03-0101-008	1
3	Pinion Gear	03-0102-006	1
4	Axle	03-0101-009	2
5	Bearing	01-0196-012	2
6	Spacer	04-0106-010	1
7	Screw, Socket Set, 1/4"- 20NC x 1/4"	19-14C0-014	1
8	Spring Pin, 3/16" x 1"	18-3160-100	1
9	Spiral Ring	01-0179-014	1

Figure 7: Double Bearing Bracket Assembly, Part # 03-0102-007

Table 7 - Double Bearing Bracket Assembly Part Identification

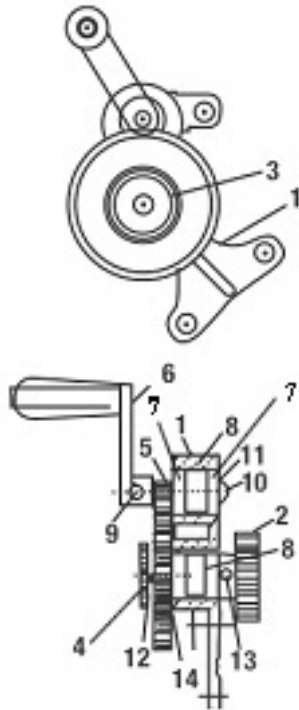

ITEM #	DESCRIPTION	PART#	QTY.
1	Bracket	03-0102-008	1
2	Pinion Gear	03-0102-006	1
3	Axle	03-0101-009	1
4	Crank Gear and Sprocket	03-0101-012	1
5	Crank Pinion	03-0101-013	1
6	Crank handle Assembly	03-0101-014	1
7	Bearing	01-0196-012	4
8	Spacer	04-0106-010	2
9	Screw, socket set, 1/4"- 20NC	19-14C0-014	3
10	Machine Screw, round head, 1/4"- 20NC x 1/2"	14-14C0-012	1
11	Washer, flat, 1/4"	12-0014-F00	1
12	Spring Pin, 1/8" x 1"	18-1800-100	1
13	Spring Pin, 3/16" x 1"	18-3160-100	1
14	Spiral Ring, 1/2"	01-0179-014	1

Figure 8 - Motorized 2SA Saddle Machine Configuration



Table 8 – Motorized 2SA Saddle Machine Parts Identification

ITEM #	DESCRIPTION	PART#	QTY.
1	2SA Saddle Machine	03-0102-000	1
	Stepper Motor Kit (components included below)	03-0101-SA1	1
2	Motor Coupling	03-0101-101	1
3	NEMA 23 Stepper Motor and Junction Box Assembly	03-0201-060	1
4	Socket Head Cap Screw, #8-32 unc x 1/2" lg.	11-08C0-012	3
5	Socket Head Set Screw, #8-32 unc x 3/16"	19-08C0-316	1
6	Button Head Socket Cap Screw, #10-24 unc x 3/4" lg.	26-10C0-034	4
7	Motor Adaptor	03-0100-064	1
8	Motor Control Box complete with motor and plasma cable (See page 13)	03-0203-008	1
9	Cable, Stepper Motor to Stepper Motor Control Box (See page 14)	03-0203-200	1
10	Cable, Plasma Stepper Motor Control Box (Not shown)	03-0203-201	1
11	Connector, NEMA 23 Stepper Motor Assembly (included in Item 3)	03-0203-115	1

Table 9 – Trouble shooting – Saddle Machine

MANUAL		
Symptom	Possible Cause(s)	Corrective Action
Machine is cutting out of square	Incorrect Spacers are used	Use only Mathey Spacer.
	Customer is cutting tubing.	Contact Mathey Dearman Sales Department for Spacers for tubing.
	The Spacers are not in contact with pipe.	Reposition machine so that both Spacers contact the pipe and re-tighten Boomer.
	Torch, Torch Arm or Torch Carrier is loose.	Tighten Wing Nuts or Thumbscrews.
	Hoses are binding.	Wrap the Hose one (1) full turn around the pipe. Rotate the Ring Gear of the machine so the Hoses unwrap during the cutting process.
	Machine has been dropped.	Send the machine to a certified repair station for resizing Cap Ring, Ring Gear and Saddle.
	Torch is at end of Torch Arm.	Move the Torch closer to the Ring Gear.
	The Pinion Gears are too shallow in the large Ring Gear.	Readjust the Pinion Gear so it is at the proper depth in Ring Gear
Machine hesitates or stops as the Pinion Gear enters the Ring Gear.	The timing of the Pinion Gears to the Ring Gear is out of adjustment.	Readjust the timing of the Pinion Gear to the Ring Gear per the repair instructions.
	The Drive Chain is stretched.	Readjust the Bearing Brackets to eliminate the slack in the Chain per the repair instructions.
		Replace the Drive Chain
MOTORIZED		
Machine does not rotate	Bad DC Cable	Replace cable
	No DC output from motor control box	Reset circuit breaker on motor control box
	No electrical power at wall receptacle	Reset circuit breaker at power panel
	Emergency stop is depressed	Rotate to release emergency stop
	Forward and reverse switch is bad	Contact Mathey Dearman
	Bad 6 pin connector on motor	Contact Mathey Dearman
Motor turns and machine does not rotate	Setscrew has backed off in coupling	Tighten setscrew

9.0 MAINTENANCE

In order to the maximum life of the 2SA Saddle machine, the maintenance should be performed by an authorized Mathey Dearman Certified Repair Center. The Mathey Dearman Pipe Cutting and Beveling Machine requires only minimal maintenance; however, these are precision machines. In order to achieve proper results, make sure your machine is handled with reasonable care and it kept clean and lubricated. The machine should be stored in a protective container such as a Mathey Dearman Machine Storage Box or the original factory shipping crate during transporting or when not in use.

The Ring Gear, Pinion Gears, and Drive Chains should be kept clear of slag and other trapped abrasives, especially sand and dirt. The Saddle, Ring Gear, and Cap Ring should be cleaned weekly and the Ring Gear Track Surfaces should be coated with **Lubriplate 130-AA** or equal lubricant weekly under heavy use and before storing. The Drive Chains and Sprockets should be cleaned regularly and coated with a film of a light oil or lubricant such as WD-40 or equal. The bearings (Figure 6 item 5) in the Single Bearing Bracket (Figure 6) and the bearings (Figure 7 item 7) in the Double Bearing Bracket (Figure 7) are sealed lubricated bearings and should never require replacement.

There are 2 thread holes in the side of the Single Bearing Bracket (Figure 6) containing a set screws (Figure 6 item 7) and 2 thread holes in the side of the Double Bearing Bracket (Figure 7) containing a set screws (Figure 7 item 9). These Set Screws should never be loosened or removed except to replace the bearings (Figure 6 item 5) (Figure 7 item 7).

Contact Mathey Dearman at 918-447-1288, should any questions arise that are not covered in the manual

9.1 Timing the Ring Gear to the Pinion Gears

9.1.1 Remove the Tie Rod Handle (Figure 5 item 6) from the Saddle (Figure 5 item 1) and Single and Double Bearing Brackets (Figure 5 items 4 & 5) by removing Hex Head Cap Screws (Figure 5 item 10 & 11) and Hex Nuts (Figure 5 item 12) using a 1/2" wrench.

NOTE: Save Hex Nuts (Figure 5 item 13) that are used as spacers between the Tie Rod Handle (Figure 5 item 6) from the Saddle (Figure 5 item 1)

9.1.2 With an 1/8" allen wrench loosen the 2 Socket Set Screws (Figure 6 item 7) in the Sprocket (Figure 6 item 2) of the Single Bearing Bracket (Figure 6).

9.1.3 Rotate the Ring Gear (Figure 5 item 3) clockwise (as viewed from the front of the machine) until the gap in the Ring Gear is at the 11:00 Position and off the Pinion Gear (Figure 6 item 3) of the Single Bearing Bracket (Figure 6) or until the Pinion Gear does not make contact with the Ring Gear.

9.1.4 Rotate the Sprocket (Figure 6 item 2) on the axle (Figure 6 item 4) of the Single Bearing Brackets (Figure 6) to make sure it is loose on the axle.

9.1.5 Rotate the Ring Gear (Figure 5 item 3) clockwise (as viewed from the front of the machine) until the gap in the Ring Gear is at the 12:00 Position.

9.1.6 Adjust the Pinion Gear (Figure 6 item 3) of the Single Bearing Brackets (Figure 6) as needed so that it enters the Ring Gear (Figure 5 item 3) without hesitation.

NOTE: When the Pinion Gear (Figure 6 item 3) of the Single Bearing Bracket (Figure 6) and Pinion Gear (Figure 7 item 2) Double Bearing Bracket (Figure 7) enters the Ring Gear (Figure 5 item 3) it should not suddenly pull the Ring Gear. As the Pinion Gear (Figure 6 item 3) of the Single Bearing Bracket (Figure 6) and Pinion Gear (Figure 7 item 2) Double Bearing Bracket (Figure 7) leaves the Ring Gear (Figure 5 item 3) it should not suddenly push the Ring Gear.

9.1.7 Move the Pinion Gear (Figure 6 item 3) of the Single Bearing Brackets (Figure 6) until the Pinion Gear (Figure 6 item 3) of the Single Bearing Brackets (Figure 6) and the Pinion Gear (Figure 7 item 2) Double Bearing Bracket (Figure 7) are evenly spaced in the teeth of the Ring Gear (Figure 5 item 3).

9.1.8 Tighten the Hex Head Cap Screws (Figure 5 item 9) on both sides of the Single Bearing Bracket Assembly Figure using a 7/16" wrench.

9.1.9 Tighten 1 of the Socket Head Set Screws (Figure 6 item 7) in the Sprocket (Figure 6 item 2) of the Single Bearing Bracket Assembly (Figure 6).

9.1.10 Rotate the Ring Gear (Figure 5 item 3) one (1) full revolution in the clockwise and counterclockwise direction checking the entry of the Ring Gear (Figure 5 item 3) into the Pinion Gear (Figure 6 item 3) of the Single Bearing Bracket (Figure 6) and Pinion Gear (Figure 7 item 2) Double Bearing Bracket (Figure 7)

NOTE: The entry of the Pinion Gears into the Ring Gear should be smooth and without hesitation.

NOTE: The Pinion Gear (Figure 6 item 3) of the Single Bearing Bracket (Figure 6) and the Pinion Gear (Figure 7 item 2) Double Bearing Bracket (Figure 7) should be evenly spaced in the teeth of the Ring Gear (Figure 5 item 3). There should be no more than .005 " / .12mm of play between the Pinion Gear (Figure 6 item 3) of the Single Bearing Bracket (Figure 6) and the Pinion Gear (Figure 7 item 2) Double Bearing Bracket (Figure 7) and the Ring Gear (Figure 5 item 3).

- 9.1.11 If entry of the Pinion Gear (Figure 6 item 3) of the Single Bearing Bracket (Figure 6) and the Pinion Gear (Figure 7 item 2) Double Bearing Bracket (Figure 7) into the Ring Gear (Figure 5 item 3) is satisfactory; tighten the 2nd Set Screw (Figure 6 item 7) in the Sprocket (Figure 6 item 2).
- 9.1.12 Place the Hex Nuts (Figure 5 item 13) over the threaded holes nearest the center of the Saddle (Figure 5 item 1). Place the Tie Rod Handle (Figure 5 item 6) over Hex Nuts (Figure 5 item 13) located over the threaded holes in the Saddle (Figure 5 item 1) and line up with the holes in the Single and Double Bearing Bracket Assemblies (Figure 5 item 4 & 5) and install and tighten the Hex Head Cap Screws (Figure 5 item 10 & 11) and Hex Nuts (Figure 5 item 12) using a 1/2" wrench.
- 9.1.13 Rotate the Ring Gear (Figure 5 item 3) one (1) full revolution in the clockwise and counterclockwise direction checking the entry of the Ring Gear (Figure 5 item 3) into the Pinion (Figure 6 item 3) of the Single Bearing Bracket (Figure 6) and the Pinion Gear (Figure 7 item 2) Double Bearing Bracket (Figure 7) to insure the entry of the Pinion Gears into the Ring Gear is smooth and without hesitation.
- 9.1.14 The machine is now ready for the cutting operation.

9.2 Installation of a New Drive Chain

- 9.2.1 Remove the Tie Rod Handle (Figure 5 item 6) as described in 9.1.1. With a 1/2" wrench loosen the Hex Head Cap Screw (Figure 5 item 9) to the left of the Single Bearing Bracket (Figure 5 item 4) as viewed from the rear of the machine.
- 9.2.2 With a 1/2" wrench loosen and remove Hex Head Cap Screw (Figure 5 item 9) to the right of the Single Bearing Bracket Assembly (Figure 5 item 4) as viewed from the rear of the machine.
- 9.2.3 Tilt the Single Bearing Bracket (Figure 5 item 4) toward the center of the machine and remove the old drive chain (Figure 5 item 16).
- 9.2.4 With an 1/8" allen wrench loosen the both Socket Set Screws (Figure 6 item 7) in the Sprocket (Figure 6 item 2) of the Single Bearing Bracket (Figure 6).
- 9.2.5 Rotate the Sprocket (Figure 6 item 2) on the axle (Figure 6 item 4) of the Single Bearing Bracket (Figure 6) until it rotates freely on the axle.
- 9.2.6 Place the new chain (Figure 5 item 16) over the sprocket of the Crank Gear and Sprocket Assembly (Figure 7 item 4) of the Double Bearing Bracket Assembly (Figure 7).
- 9.2.7 Place the chain (Figure 5 item 16) over the sprocket (Figure 6 item 2) of the Single Bearing Bracket Assembly (Figure 6).
- 9.2.8 Rotate the Single Bearing Bracket Assembly (Figure 6) clockwise while rotating the Pinion Gear (Figure 6 item 3) so that it meshes into the Ring Gear (Figure 5 item 3).
- 9.2.9 Insert the Hex Head Cap Screw (Figure 5 item 9) in the hole on the right of the Single Bearing Bracket Assembly (Figure 5 item 4) and hand tighten only at this time.
- 9.2.10 With a 1/2" wrench tighten, the Hex Head Cap Screw (Figure 5 item 9) to the left of the Single Bearing Bracket Assembly (Figure 5 item 4) as viewed from the rear of the machine.
- 9.2.11 Adjust teeth of the Pinion Gear (Figure 6 item 3) of the Single Bearing Brackets (Figure 6) and the Pinion Gear (Figure 7 item 2) of the Double Bearing Bracket (Figure 7) so they are evenly spaced in the teeth of the Ring Gear (Figure 5 item 3). There should be no more than .005" / .12mm of play between the Pinion Gear (Figure 6 item 3) of the Single Bearing Bracket (Figure 6) or the Pinion Gear (Figure 7 item 2) of the Double Bearing Bracket (Figure 7) and the Ring Gear (Figure 5 item 3).
NOTE: If the desired chain tension cannot be attained it may be necessary to adjust the Double Bearing Bracket in the same manor.
- 9.2.12 With a 1/2" wrench tighten Hex Head Cap Screw (Figure 5 item 9) to the right of the Single Bearing Bracket (Figure 5 item 4).
- 9.2.13 Tighten 1 of the Socket Head Set Screws (Figure 6 item 7) in the Sprocket (Figure 6 item 2) of the Single Bearing Bracket Assembly (Figure 6) to fix it to the Axle.
- 9.2.14 Rotate the Ring Gear (Figure 5 item 3) one (1) full revolution in the clockwise and counterclockwise direction checking the entry of the Ring Gear into the Pinion Gear (Figure 6 item 3) of the Single Bearing Bracket (Figure 6) and the Pinion Gear (Figure 7 item 2) of the Double Bearing Bracket (Figure 7).
NOTE: The entry of the Pinion Gears into the Ring Gear should be smooth and without hesitation.
NOTE: The Pinion Gear (Figure 6 item 3) of the Single Bearing Bracket (Figure 6) and the Pinion Gear (Figure 7 item 2) of the Double Bearing Bracket (Figure 7) should be evenly spaced in the teeth of the Ring Gear (Figure 5 item 3). There should be no more than .005" play between the Pinion Gears and the Ring Gear (Figure 5 item 3).
- 9.2.15 Reinstall the Tie Rod Handle (Figure 5 item 6) as mentioned in 9.1.12.

- 9.2.16 Recheck the entry of the Ring Gear (Figure 5 item 3) into the Pinion Gear (Figure 6 item 3) of the Single Bearing Bracket (Figure 6) and the Pinion Gear (Figure 7 item 2) of the Double Bearing Bracket (Figure 7).
- 9.2.17 The machine is now ready for the cutting operation.

9.3 Retiming of the Machine with Stepper Motor

- 9.3.1 Remove #8-32 x ½" lg. Socket Head Cap Screws (Figure 8 item 4) that attach the Motor Adaptor (Figure 8 item 7) to the Double Bearing Bracket Assembly (Figure 5 item 5) of the 2SA Saddle Machine.
- 9.3.2 Grasp the Motor Adaptor (Figure 8 item 7) and remove the Motorizing kit from the Double Bearing Bracket Assembly (Figure 5 item 5)
- 9.3.3 Loosen the #8-32 Socket Head Set Screw (Figure 8 item 5) located in the Motor Coupling (Figure 8 item 2).
- 9.3.4 Remove the Motor Coupling.
- 9.3.5 Install the Crank Handle Assembly (Figure 7 Item 6).
- 9.3.6 Follow instruction in section 9.1 on page 21.
- 9.3.7 Reverse steps 9.3.1 thru 9.3.4.
- 9.3.8 Place the machine on a pipe.
- 9.3.9 Connect the Motor Cable to the Motor Assembly (Figure 8 item 3) and to the Motor Control Box.
- 9.3.10 Depress the Emergency Stop Switch.
- 9.3.11 Move the Directional Control Switch to the "Off" position.
- 9.3.12 Plug the Motor Control Box into a wall outlet having an output of 90 to 240 volts AC.
- 9.3.13 Twist to release the Emergency Stop Switch.
- 9.3.14 The Digital Screen will light up showing the following.
 - 991 – Indicates the stepper motor is NEMA 23
 - 992 – Indicates the Stepper Motor is NEMA 34
 - 993 – Indicates the Stepper Motor is a heavy-duty NEMA
 - 994 & 995 – Check cable connection at motor and motor control box.
 - 999 – Indicates the Directional Control Switch is in the "Forward" or "Reverse" position. Move to the "Off" position.

NOTE: If any other codes appear contact Mathey Dearman prior to continuing the cutting process.

- 9.3.15 If no faults are present after the motor number appears, the percent of maximum speed will be displayed in the window.
- 9.3.16 Move the Directional Control Switch to the "Forward" or "Reverse" direction.
- 9.3.17 Depress the Speed Control Switch until the percent of motor speed reads about 32% so control of the machine can be maintained should an emergency arise.
- 9.3.18 If the motorized unit is operating improperly see the trouble shooting in Table 9.

9.4 Replacement of Drive Chain of the Machine with Stepper Motor

- 9.4.1 Remove #8-32 x ½" lg. Socket Head Cap Screws (Figure 8 item 4) that attach the Motor Adaptor (Figure 8 item 7) to the Double Bearing Bracket Assembly (Figure 5 item 5) of the 2SA Saddle Machine.
- 9.4.2 Grasp the Motor Adaptor (Figure 8 item 7) and remove the Motorizing kit from the Double Bearing Bracket Assembly (Figure 5 item 5).
- 9.4.3 Loosen the #8-32 Socket Head Set Screw (Figure 8 item 5) located in the Motor Coupling (Figure 8 item 2).
- 9.4.4 Remove the Motor Coupling.
- 9.4.5 Install the Crank Handle Assembly (Figure 7 Item 6).
- 9.4.6 Follow instruction in section 9.2 on page 22.
- 9.4.7 Reverse steps 9.4.1 thru 9.4.4.
- 9.4.8 Place the machine on a pipe.
- 9.4.9 Connect the Motor Cable to the Motor Assembly (Figure 8 item 3) and to the Motor Control Box.
- 9.4.10 Depress the Emergency Stop Switch.
- 9.4.11 Move the Directional Control Switch to the "Off" position.
- 9.4.12 Plug the Motor Control Box into a wall outlet having an output of 90 to 240 volts.
- 9.4.13 Twist to release the Emergency Stop Switch.
- 9.4.14 The Digital Screen will light up showing the following.
 - 991 – Indicates the stepper motor is NEMA 23.
 - 992 – Indicates the Stepper Motor is NEMA 34.
 - 993 – Indicates the Stepper Motor is a heavy-duty NEMA.
 - 994 & 995 – Check cable connection at motor and motor control box.
 - 999 – Indicates the Directional Control Switch is in the "Forward" or "Reverse" position. Move to the "Off" position.

NOTE: If any other codes appear contact Mathey Dearman prior to continuing the cutting process.

- 9.4.15 If no faults are present after the motor number appears, the percent of maximum speed will be displayed in the window.
- 9.4.16 Move the Directional Control Switch to the "Forward" or "Reverse" direction.

- 9.4.17 Depress the Speed Control Switch until the percent of motor speed reads about 32% so control of the machine can be maintained should an emergency arise.
- 9.4.18 If the motorized unit is operating improperly see the trouble shooting in Table 9.

9.5 Installation of the Stepper Motor Kit

- 9.5.1 Loosen the set screw in the Crank Handle Assembly (Figure 7 item 6).
- 9.5.2 Remove the Crank Handle Assembly (Figure 7 item 6) from the shaft of the Crank Pinion (Figure 7 item 5).
- 9.5.3 Make sure the 3 threaded holes in the face of Double Bearing Bracket (Figure 7 item 1) are not damaged and free of debris.
- 9.5.4 Install the Motor Coupling (Figure 8 item 2) on to the shaft of the Crank Pinion (Figure 7 item 5).
- 9.5.5 Tighten the #8-32 Set screw (Figure 8 item 5) located in the Motor Coupling (Figure 8 item 2).
- 9.5.6 Slide the Motor Adaptor (Figure 8 item 7) over the Motor Coupling (Figure 8 item 2) and align the Motor Adaptor holes with the threaded holes in the face of the Double Bearing Bracket.
- 9.5.7 Place the #8-32 Socket Head Screws (Figure 8 item 4) into the holes of the Motor Adaptor (Figure 8 item 7) and thread them into the Double Bearing Bracket.
- 9.5.8 Align the hole in the Motor Coupling (Figure 8 item 2) with the flat on the shaft of the Motor Assembly (Figure 8 item 3) and insert the motor shaft in the Motor Coupling until the face of the Motor Assembly is flush with the face of the Motor Adaptor (Figure 8 item 7).
- 9.5.9 Install the #10-24 Button Head Socket Cap Screws (Figure 8 item 6) through the holes in the Motor Assembly (Figure 8 item 3) and thread them into the thread holes of the Motor Adaptor (Figure 8 item 7).
- 9.5.10 Place the machine on a pipe.
- 9.5.11 Connect the Motor Cable to the Motor Assembly (Figure 8 item 3) and to the Motor Control Box.
- 9.5.12 Depress the Emergency Stop Switch.
- 9.5.13 Move the Directional Control Switch to the "Off" position.
- 9.5.14 Plug the Motor Control Box into a wall outlet having an output of 90 to 240 volts.
- 9.5.15 Twist to release the Emergency Stop Switch.
- 9.5.16 The Digital Screen will light up showing the following.
- 991 – Indicates the stepper motor is NEMA 23.
 - 992 – Indicates the Stepper Motor is NEMA 34.
 - 993 – Indicates the Stepper Motor is a heavy-duty NEMA.
 - 994 & 995 – Check cable connection at motor and motor control box.
 - 999 – Indicates the Directional Control Switch is in the "Forward" or "Reverse" position. Move to the "Off" position.

NOTE: If any other codes appear contact Mathey Dearman prior to continuing the cutting process.

- 9.5.17 If no faults are present after the motor number appears, the percent of maximum speed will be displayed in the window.
- 9.5.18 Move the Directional Control Switch to the "Forward" or "Reverse" direction.
- 9.5.19 Depress the Speed Control Switch until the percent of motor speed reads about 32% so control of the machine can be maintained should an emergency arise.
- 9.5.20 If the motorized unit is operating improperly see the trouble shooting in Table 9.

9.6 Disassembly and Repair of the Single and Double Bearing Bracket Assemblies.

Contact Mathey Dearman for instructions, if disassembly and repair of the Single and Double Bearing Bracket Assemblies is required

9.7 Storage

If the machine will not be used for a period of the time, the machine should be cleaned and regreased with Lubriplate 130-AA. The machine should be stored in a clean and dry place protected from damage.

10.0 LIMITATIONS

Mathey Dearman is not and will not be responsible for

- Improper use of the Saddle Machine.
- Use of the Saddle Machine in violation of any national and/or international electrical and safety regulations in force.
- Connection of the Motorized Saddle Machine to an improper or wrong power source.
- Faulty maintenance.
- Unauthorized modification and/or service of the Saddle Machine.
- Use of non-original spare parts or non-specific components.
- Lack of observance or partial observance of the operating and maintenance instructions.
- Unusual events such as natural disasters, wars, strikes or similar events.

11.0 MACHINE SAFETY

Users should follow these standard safety procedures in order to observe and prevent the safety of all employees using the machine:

- Operators must use the wear safety goggles and shoes and should be suitably dressed for the working environment. Operators and maintenance personnel should read and understand the Parts and Operating Manual prior to attempting any type of function.
- Check the electrical connections prior to operating the Motorized Saddle Machine.
- Turn off the electrical power source prior to disconnecting the electrical connector from the power source.
- Observe all health warnings listed in the Parts and Operating Manual.

12.0 CONDITION OF USE

12.1 Condition of use

- The purpose of the Saddle Machine is indicated on section 2.1. Any other use, different from what is listed in section 2.1, could be hazardous to the operator.
- The Saddle Machine should be placed in a safe place protected from rain, extreme humidity, mud or accidental impact.
- The Saddle Machine should never be operated in an extremely humid environment such as fog or rain.
- Adopt all the safety devices supplied or suggested by the manufacturer.
- No modification to the Saddle Machine or its accessories should be done without the previous written approval by the manufacturer.
- Remember the Motor Control Box is attached to the power source current is applied to the motor control box. The Motor Control Box should be disconnected from the power source when not in use.

12.2 Use of the Saddle Machine not allowed by the Manufacturer

- Tampering with the electrical circuit of the Motorized Saddle Machine.
- Operation of the Saddle without the appropriate safety devices.
- Perform maintenance with electrical current applied to the Saddle Machine.
- Use of a liquid or foam fire extinguisher to extinguish a fire in or near the Saddle Machine.

13.0 DISPOSAL OF THE SADDLE MACHINE

13.1 General Information

Do not dispose of any components recklessly without regard for the environment. Separate the components by category for a possible reuse. All national and state regulations should be followed when disposing of waste.

13.2 Composition of the Major Components

Component Description	Material
Saddle, Cap Ring, Ring Gear, Single & Double Bearing Bracket, Step Spacers, Motor Mounting Adaptor, Chain Guard, Motor Coupling, Motor Control Box Housing	Aluminum
Pinion Gear, Boomer, Boomer Chain, Spring, Spring Snap, Axles	Steel
Drive Chain, Crank Gear and Sprocket, Spacer Bolts, Bearings, Electrical Cords	Rubber coated copper
Cord Retention Holder	Plastic

14.0 WARRANTY

For Warranty Information visit www.mathey.com

Table 10 – Commercial Pipe Sizes and Wall Thickness

Pipe Size	OD (inches)	Nominal Wall Thickness for Schedule								
		10	20	40	Extra Strong	80	120	140	160	XX Strong
6	6 ⁵ / ₈	.134	--	.280	.432	.432	.562	--	.718	.864
8	8 ⁵ / ₈	.148	.250	.322	.500	.500	.718	.812	.906	.875
10	10 ³ / ₄	.165	.250	.365	.500	.594	.843	1.000	1.125	--
12	12 ³ / ₄	.180	.250	.406	.500	.688	1.000	1.125	1.312	--